

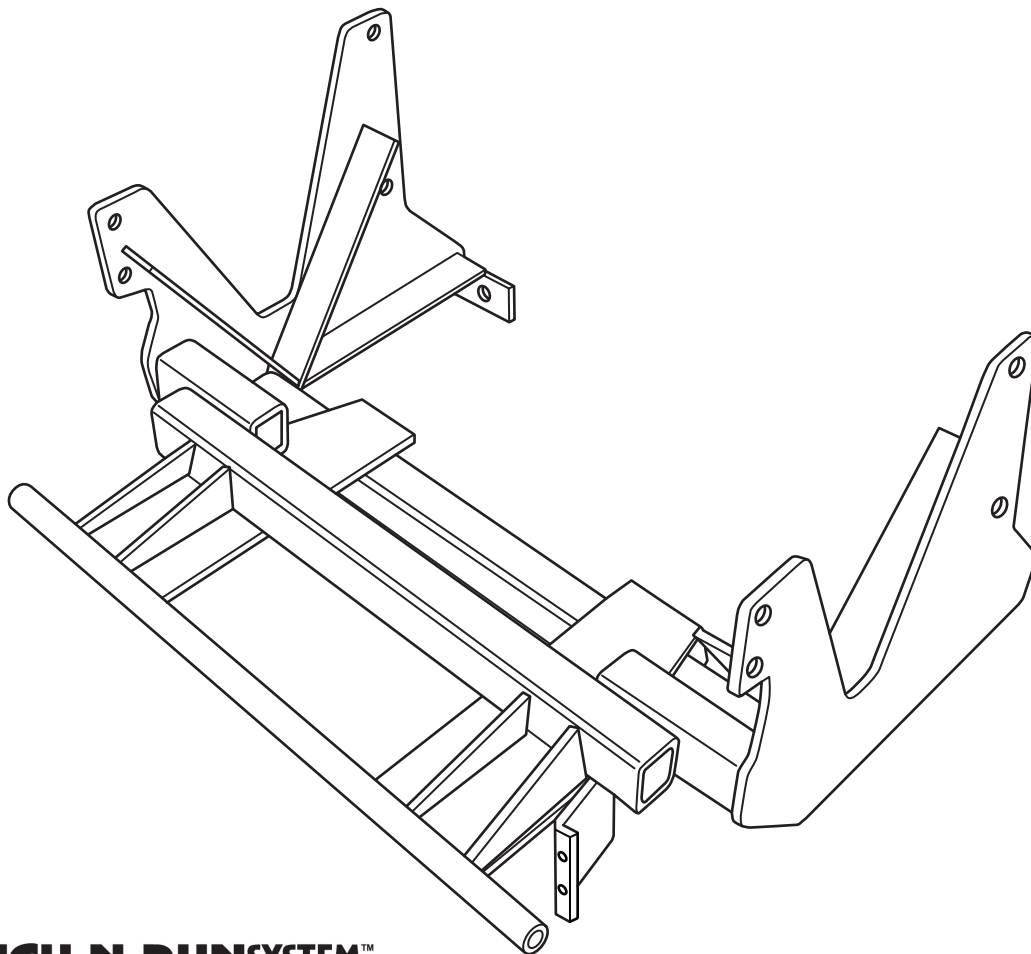

SNO-PRO[®] 3000

**2002 – 2005 Dodge Ram 1500 4WD
(With Max. GVWR. ONLY)**

Vehicle Mounting Kit: 1FK19



Revised 19 February 2014

Curtis Industries Inc. LLC, 111 Higgins St., Worcester, MA 01606 TEL: (800) 343-7676 FAX: (508) 854-3377 For Parts and information visit us at www.Curtisindustries.net
Curtis Industries Inc. LLC, reserves the right to change product design or specifications without notice or liability.
Curtis Snow Plows are protected by the following U.S. Patent Numbers: 6,145,222 and 6,209,231 Licensed under U.S. Patent Number 5,568,694 & Canadian Patent Number 2,137,853.
Other patents pending.

1FK19 Vehicle Mount Kit Parts List

Item #	Description	Qty.
1	Front Mount Frame	1
2	Bolting Bar	2
3	Spacer Bar	2
Hardware Bag Components Included In This Kit		
4	1/2"-13 x 4" Bolt, Gr.5, Plated	4
5	1/2"-13 x 4-1/2" Bolt, Gr.5, Plated	4
6	1/2" Flat Washer, Plated	8
7	1/2" Lock Washer, Plated	8
8	1/2"-13 Hex Nut, Plated	8
9	5/8"-11 x 2-1/2" Carriage Bolt, Gr.5, Plated	2
10	5/8" Lock Washer, Plated	2
11	5/8"-11 Hex Jam Nut, Plated	4
Hardware Components Included In Plow Kit		
1a	Plug Mount Bracket	1
-	10-32 x 3/4" Hex Head Screw, Plated	2
-	10-32 Nylock Lock Nut, Plated	2
-	8-32 x 1" Hex Head Screw, Plated	1
-	8-32 Nylock Lock Nut, Plated	1
-	#8 Nylon Flat Washer, 3/4" O.D.	1
-	#8 Flat Washer, SAE, Plated	1



WARNING

It is highly recommended that front "helper springs", "airshocks", or other similar devices be installed onto this vehicle to prevent the front suspension from "bottoming out" while carrying a snow plow.

Vehicle must be properly "ballasted" by placing ballast weight behind the centerline of Rear Axle so that no more than 62% of the total weight of the Vehicle, Snow Plow, Driver, Ballast weight, (and any cargo) is placed on the Front Axle while at the same time not exceeding the Gross Vehicle Weight Rating and Front or Rear Gross Axle Weight Ratings.

1FK19 Mounting

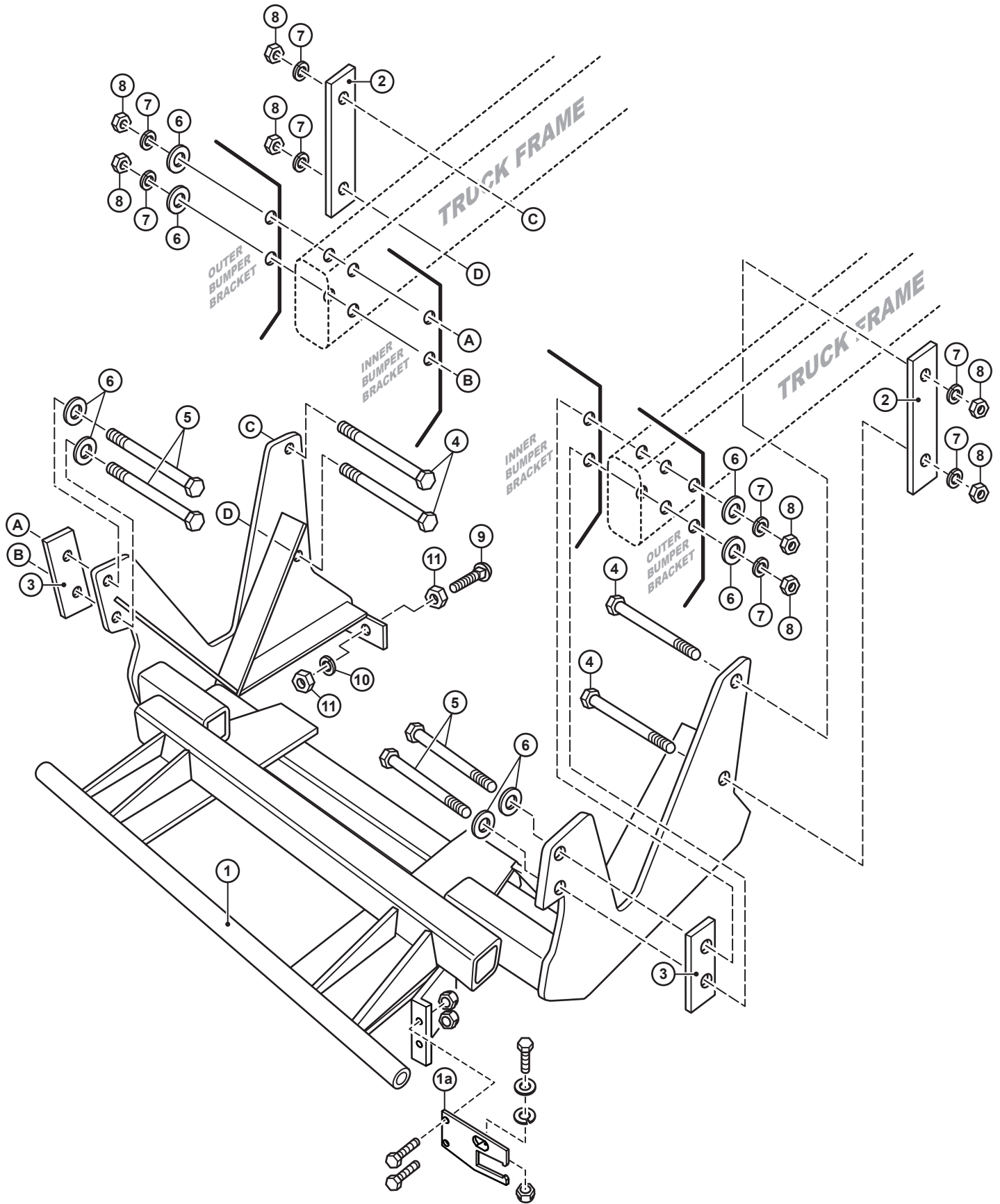

Curtis Industries, LLC. reserves the right to change product design or specifications without notice or liability. Curtis Snow Plows and Truck equipment should only be used on vehicles equipped with the manufacturer's Snow Plow preparation package. Snow Plowing without the original snow plow preparation package may damage your vehicle and the added weight of the equipment may impair the operation and control of the vehicle.

1FK19: 2002 – 2005 Dodge Ram 1500 4WD

Mounting Kit Installation Instructions

1. VEHICLE PREPARATION

- (1a.) Remove and discard the horizontal fasteners holding the front bumper to the vehicle frame rails. Remove the front bumper. If the front bumper has an attached air dam, either remove it completely, or trim out a section 32" long from the center of it.
- (1b.) Screw a 5/8"-11 hex jamb nut (11) all the way onto each of the 5/8"-11 x 2-1/2" carriage bolts (9). Place each carriage bolt / jamb nut assembly into the push ears at the rear of the mounting frame (1) with the heads of the carriage bolts toward the rear of the vehicle. Fasten loosely using a 5/8"-11 jamb nut (11), and 5/8" lock washer (10) on each carriage bolt / jamb nut assembly.

carriage bolts (9) in place by tightening the front 5/8"-11 jamb nuts (11).

3. FINAL ADJUSTMENT AND INSPECTION

Inspect the vehicle and mounting attachment bolts to be certain that they are all in place and that they are all tight.



NOTE

All fasteners should remain loose or "finger tight" until all components have been attached to vehicle or installation instructions specify tightening.

2. MOUNTING FRAME

- (2a.) Lift the mounting frame (1) up under the front of the vehicle with the vertical plates between the vertical inner surfaces of the frame rails and with the holes in the front vertical plates lined up with the two holes through each frame rail that the front bumper was attached to.
- (2b.) Temporarily fasten the mounting frame (1) through the frame rails (at the bumper mounting holes) using 1/2"-13 x 4-1/2" bolts (5). Insert 1/2"-13 x 4" bolts (4) through the two rear holes in each vertical plate of the mounting frame (1) (one bolt should pass over the top of each frame rail and one under the rail).
- (2c.) Place the bolting bar (2) over the threaded ends of the 1/2"-13 x 4-1/2" bolts (5) over and under each frame rail. Fasten using 1/2" lock washers (7) and 1/2"-13 nuts (8). Remove the 1/2"-13 x 4-1/2" bolts (5) that were temporarily installed in the front vertical plates of the mounting frame (1).
- (2d.) **VEHICLES WITH TOW HOOKS ONLY:** Reinstall the vehicle front bumper with the front vertical plates of the mounting frame (1) against the inside surface of the tow hook brackets.
- (2e.) **VEHICLES WITHOUT TOW HOOKS ONLY:** Reinstall the vehicle front bumper back onto the frame rails with the holes in the bumper brackets lined up with the holes in the frame rails. Insert the front frame spacer bars (3) between the inside surfaces of the bumper brackets and the vertical plates of the mounting frame (1).
- (2f.) **ALL VEHICLES:** Place a 1/2" flat washer (6) onto each of the 1/2"-13 x 4-1/2" bolts (5) then insert them through the vertical plates of the mounting frame (1), (inner tow hook brackets if applicable) inner bumper brackets, inner & outer frame rails, and outer bumper brackets. Fasten using 1/2" flat washers (6), 1/2" lock washers (7), and 1/2"-13 nuts (8). Slide the vehicle front bumper all the way up in its adjustment slots and tighten the four 1/2"-13 x 4-1/2" bolts (5) and nuts (8). Tighten the 1/2"-13 x 4-1/2" bolts (5) and nuts (8) installed in the rear vertical plates of the mounting frame (1) and through the bolting bar (2). Adjust the 5/8"-11 x 2-1/2" carriage bolts (9) using the rear 5/8"-11 jamb nuts (11) so that the heads of the carriage bolts are tight against the heads of the two outer bolts in the front of the vehicle front suspension cross member. Lock the 5/8"-11 x 2-1/2"