



HOME-PRO® 3000

**2005 - Toyota Tundra, Reg. Cab, V6
Automatic Transmission (With Max. GVWR & Max. FGAWR ONLY)**

Vehicle Mounting Kit: 1FK36

Revised 15 February 2011

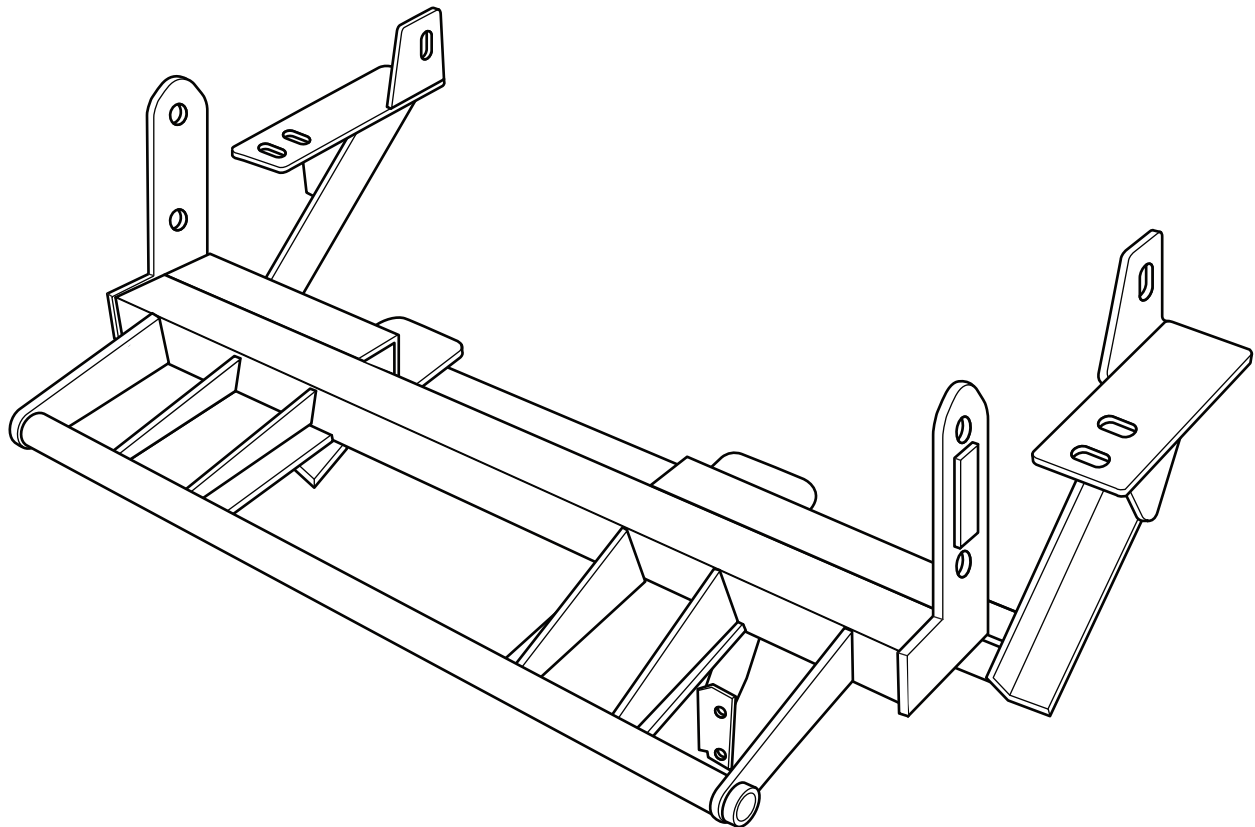

Curtis Industries Inc. LLC, 111 Higgins St., Worcester, MA 01606 TEL: (800) 343-7676 FAX: (508) 854-3377 For Parts and information visit us at www.Curtisindustries.net
Curtis Industries Inc. LLC, reserves the right to change product design or specifications without notice or liability.
Curtis Snow Plows are protected by the following U.S. Patent Numbers: 6,145,222 and 6,209,231 Licensed under U.S. Patent Number 5,568,694 & Canadian Patent Number 2,137,853.
Other patents pending.

1FK36 Vehicle Mount Kit Parts List

Item #	Description	Qty.
1	Mounting Frame	1
2	5/8"-11 Nut Bar	2
3	Frame Hanger Clamp Plate	2
Hardware Bag Components Included In This Kit		
4	1/2"-13 x 5" Hex Head Bolt, Gr. 5, Plated	4
5	1/2" Lock Washer, High Strength, Plated	4
6	1/2"-13 Hex Nut, Plated	4
7	5/8"-11 x 1-1/2" Hex Head Bolt, Gr. 5, Plated	2
8	5/8" Flat Washer, Plated	2
9	5/8" Lock Washer, High Strength, Plated	2
10	12mm x 1.25mm x 35mm Hex Head Bolt, Gr. 10.9, Plated	4
11	12mm Flat Washer, Plated	4
12	12mm Lock Washer, High Strength, Plated	4
Hardware Components Included In Plow Kit		
1a	Dual Plug Harness Bracket	1
-	10-32 x 3/4" Hex Head Screw, Plated	2
-	10-32 Nylock Lock Nut, Plated	2
-	8-32 x 1" Hex Head Screw, Plated	1
-	8-32 Nylock Lock Nut, Plated	1
-	#8 Nylon Flat Washer, 3/4" O.D.	1
-	#8 Flat Washer, SAE, Plated	1



WARNING

It is highly recommended that front "helper springs", "airshocks", or other similar devices be installed onto this vehicle to prevent the front suspension from "bottoming out" while carrying a snow plow.

Vehicle must be properly "ballasted" by placing ballast weight behind the centerline of Rear Axle so that no more than 62% of the total weight of the Vehicle, Snow Plow, Driver, Ballast weight, (and any cargo) is placed on the Front Axle while at the same time not exceeding the Gross Vehicle Weight Rating and Front or Rear Gross Axle Weight Ratings.

1FK36 Mounting

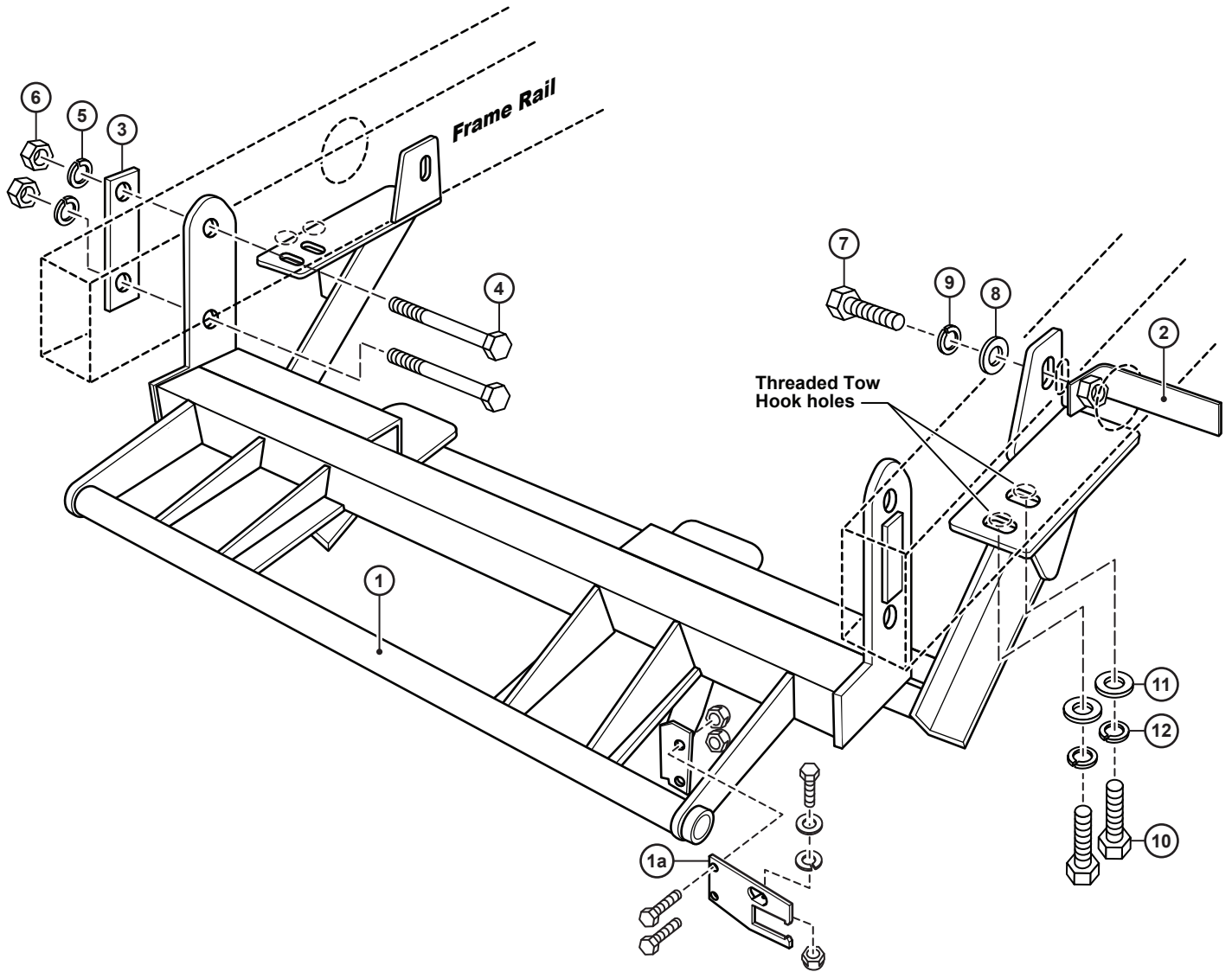

Curtis Industries, LLC. reserves the right to change product design or specifications without notice or liability. Curtis Snow Plows and Truck equipment should only be used on vehicles equipped with the manufacturer's Snow Plow preparation package. Snow Plowing without the original snow plow preparation package may damage your vehicle and the added weight of the equipment may impair the operation and control of the vehicle.

1FK36: 2005 - Toyota Tundra V6

Mounting Kit Installation Instructions

1. VEHICLE PREPARATION

(1a.) Remove and store the original equipment front skid / splash pan, the tie down bracket & fasteners on the driver's side frame rail and the tow hook / tie down bracket & fasteners on the passenger's side frame rail just behind the front bumper. Save all the original equipment parts and fasteners for possible reinstallation if the plow mounting is removed. The skid / splash pan, tie down brackets, tow hook, and fasteners will not be re-installed with the mounting frame (1) attached.



NOTE

All fasteners should remain loose or "finger tight" until all components have been attached to Vehicle or installation instructions specify tightening.

IMPORTANT

If the plow mounting frame (1) is ever removed from the vehicle, the original equipment skid / splash pan must be reinstalled before the vehicle is put back into service.

2. MOUNTING FRAME

- (2a.) Lift the mounting frame (1) up between the frame rails under the front of the vehicle with the slotted holes in the front end of the rear brackets lined up with the 12mm-1.25mm threaded holes that the tie down brackets and tow hook were fastened to. Fasten loosely using 12mm-1.25mm x 35mm bolts (10), 12mm flat washers (11) and 12mm lock washers (12). Place a 1/2"-13 x 5" bolt (4) through the upper and lower holes in each front hanger bracket at the front of the mounting frame (1) (upper bolts go over the top of frame rails – lower bolts go under frame rails).
- (2b.) Install a frame hanger clamp plate (3) over the ends of the 1/2"-13 x 5" bolts (4) on the outside of each frame rail. Fasten loosely using 1/2" lock washers (5) and 1/2"-13 nuts (6). Insert a 5/8"-11 nut bar (2) into the large hole in the outside surface of each frame rail just ahead of the front suspension cross member. Place a 5/8" lock washer (9) and 5/8" flat washer (8) onto each of the 5/8"-11 x 1-1/2" bolts (7) and insert through the slotted hole in the vertical ears of each rear bracket on the mounting frame, each frame rail, and thread into the previously installed 5/8"-11 nut bars (2).
- (2c.) Tighten all fasteners fully starting with the 12mm-1.25mm x 35mm bolts (10).

3. FINAL ASSEMBLY AND INSPECTION

Inspect the mounting attachment bolts to be certain that they are all in place and that they are all tight.

4. OPTIONAL PLUG MOUNT BRACKET INSTALL

Install the Plug Mount Bracket if the harness will be mounted on the frame kit, otherwise, the harness may be routed through the grill, bumper, etc.

Using (2) 10-32 x 3/4" hex bolts and nylon locknuts, fasten the Plug Mount Bracket to the Plug Mount Bracket Mounting Tab located on the drivers side of the frame kit receiver. The included 8-32 hardware is used for mounting the hi-amp battery leads to the Plug Mount Bracket, if used.

