

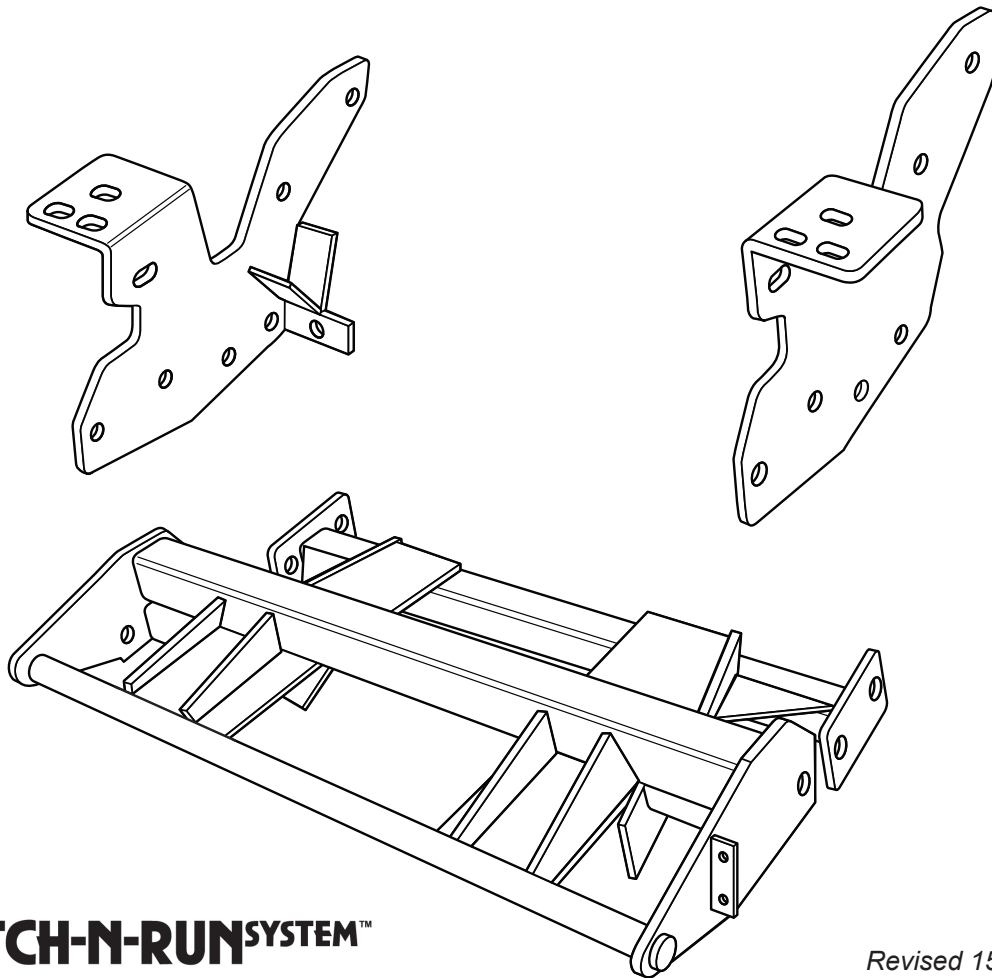

SNO-PRO[®] 3000

**2011 Ford Super Duty F-250, F-350 & F-450
2008-2010 Ford Super Duty F-250, F-350
(With Snow Plow Prep. Package ONLY)**

Vehicle Mounting Kit: 1FK42



Revised 15 February 2011

Curtis Industries Inc. LLC, 111 Higgins St., Worcester, MA 01606 TEL: (800) 343-7676 FAX: (508) 854-3377 For Parts and information visit us at www.Curtisindustries.net
Curtis Industries Inc. LLC, reserves the right to change product design or specifications without notice or liability.
Curtis Snow Plows are protected by the following U.S. Patent Numbers: 6,145,222 and 6,209,231 Licensed under U.S. Patent Number 5,568,694 & Canadian Patent Number 2,137,853.
Other patents pending.

1FK42 Vehicle Mount Kit Parts List

Item #	Description	Qty.
1	Mounting Frame	1
2	Driver's Side Push Arm	1
3	Passenger's Side Push Arm	1
Hardware Bag Components Included In This Kit		
4	5/8"-11 x 1-1/2" Strap Bolt	4
5	5/8"-11 x 2" Bolt, Grade 5, Plated	8
6	1/2"-13 x 1-1/2" Bolt, Grade 5, Plated	2
7	1/2" Lock Washer, High Strength, Plated	2
8	1/2-13" Hex Nut, Plated	2
9	1/2" Flat Washer	2
10	5/8"-11 x 3" Carriage Bolt, Grade 5, Plated	2
11	5/8" Lock Washer, High Strength, Plated	14
12	5/8"-11 Hex Jam Nut, Plated	4
13	5/8"-11 Hex Nut, Plated	12
Hardware Components Included In Plow Kit		
1a	Dual Plug Harness Bracket	1
-	10-32 x 3/4" Hex Head Screw, Plated	2
-	10-32 Nylock Lock Nut, Plated	2
-	8-32 x 1" Hex Head Screw, Plated	1
-	8-32 Nylock Lock Nut, Plated	1
-	#8 Nylon Flat Washer, 3/4" O.D.	1
-	#8 Flat Washer, SAE, Plated	1

Figure 1. Bumper Modification (2011 Ford F-250 shown)

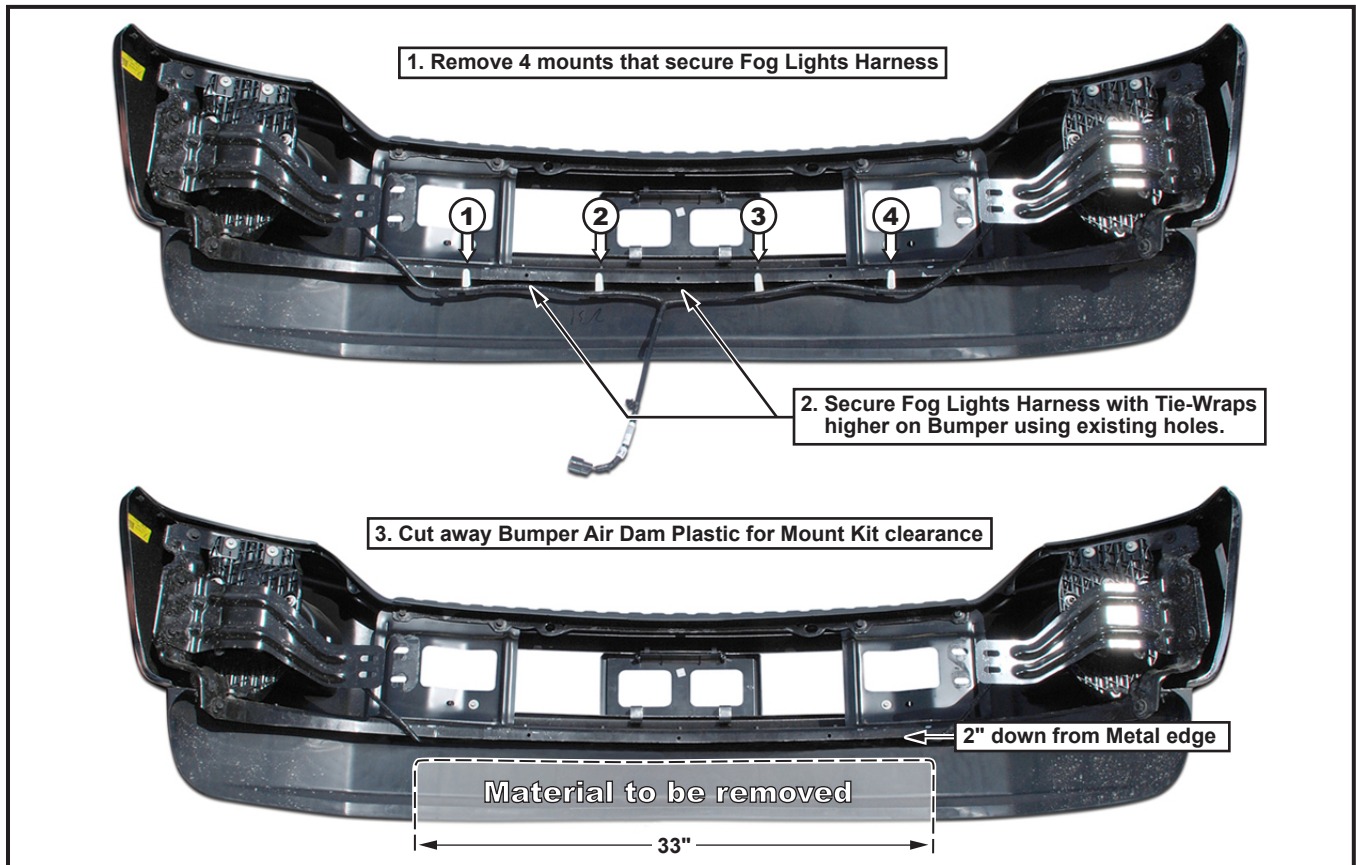

1FK42 Figure 2: Mounting

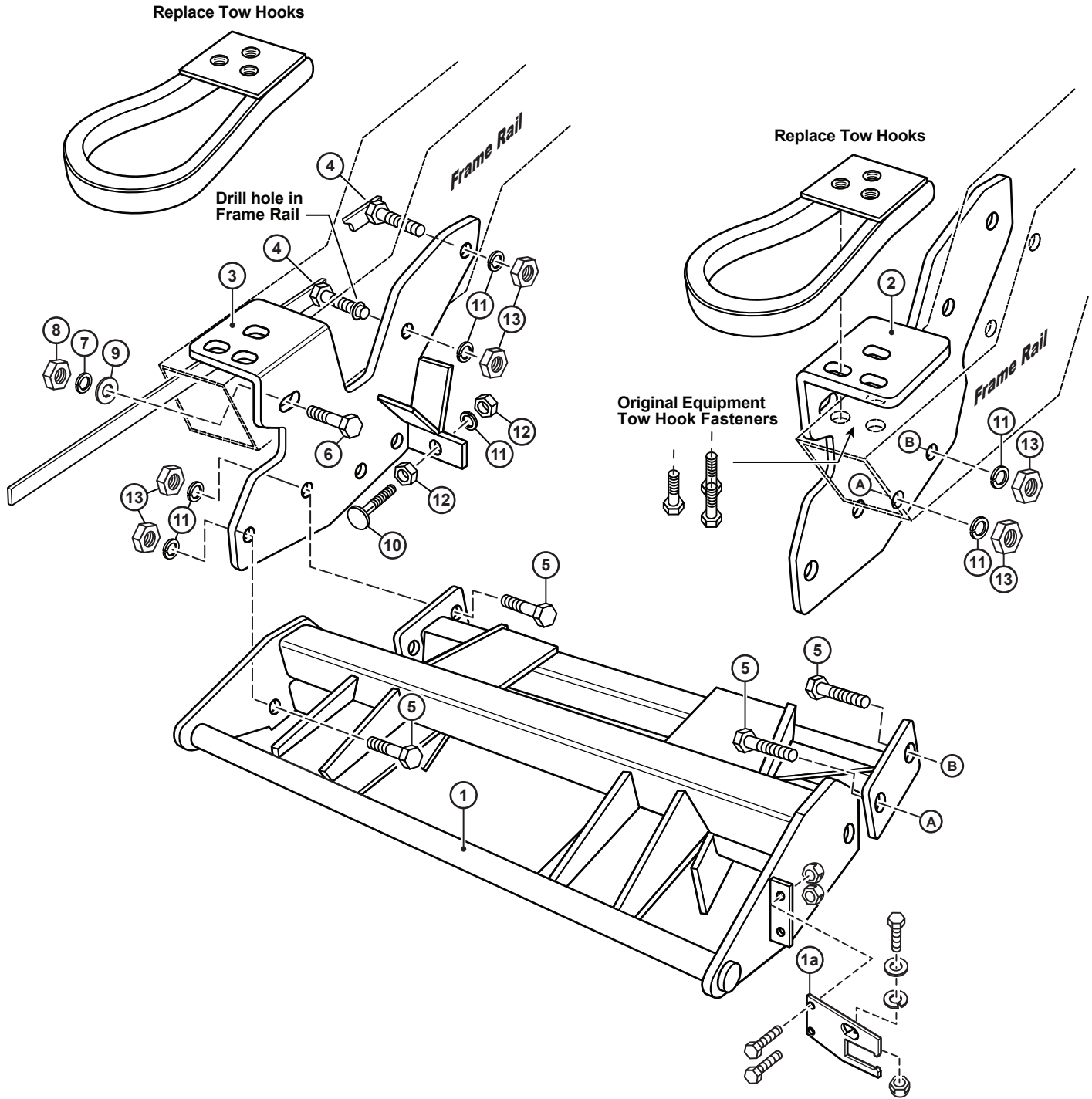

Curtis Industries, LLC. reserves the right to change product design or specifications without notice or liability. Curtis Snow Plows and Truck equipment should only be used on vehicles equipped with the manufacturer's Snow Plow preparation package. Snow Plowing without the original snow plow preparation package may damage your vehicle and the added weight of the equipment may impair the operation and control of the vehicle.

1FK42: 2008-2011 Ford Super Duty

Figure 3. Vehicle Preparation for Mount Kit

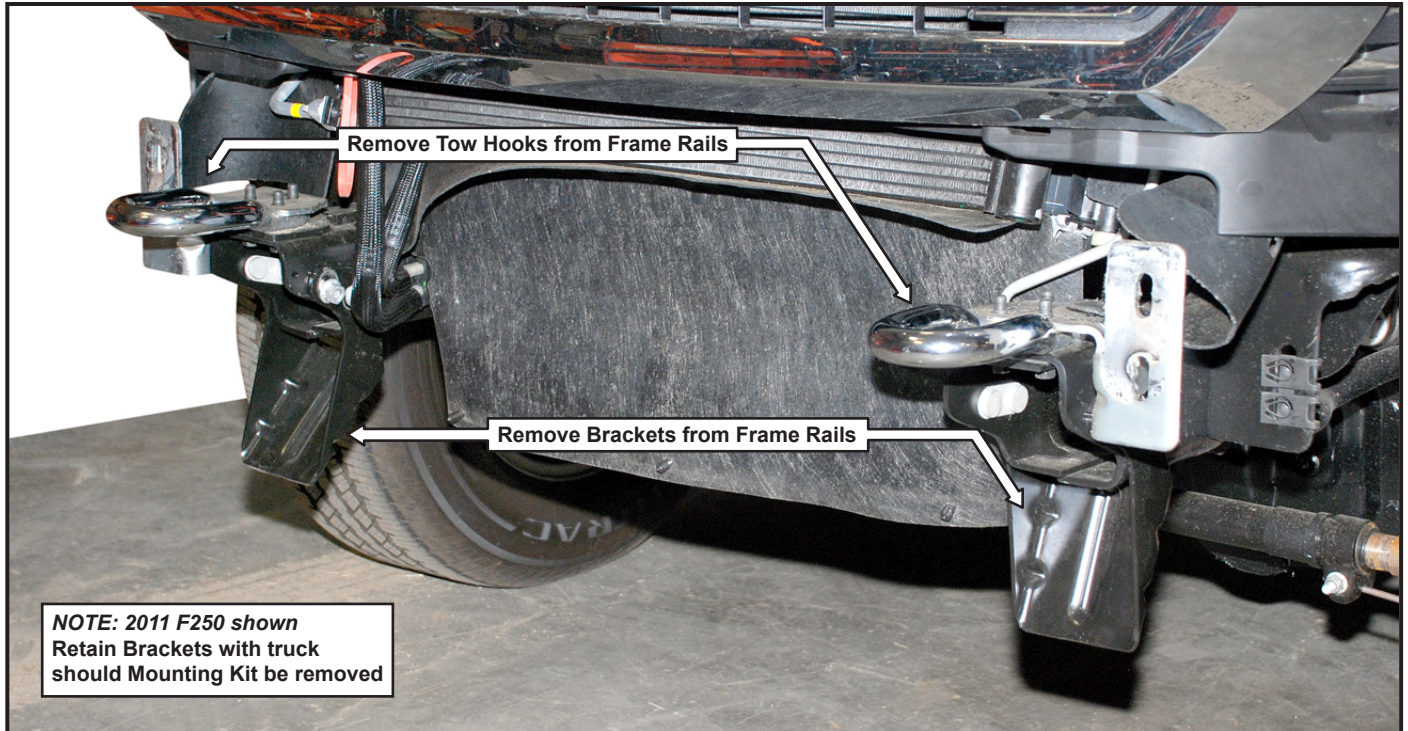
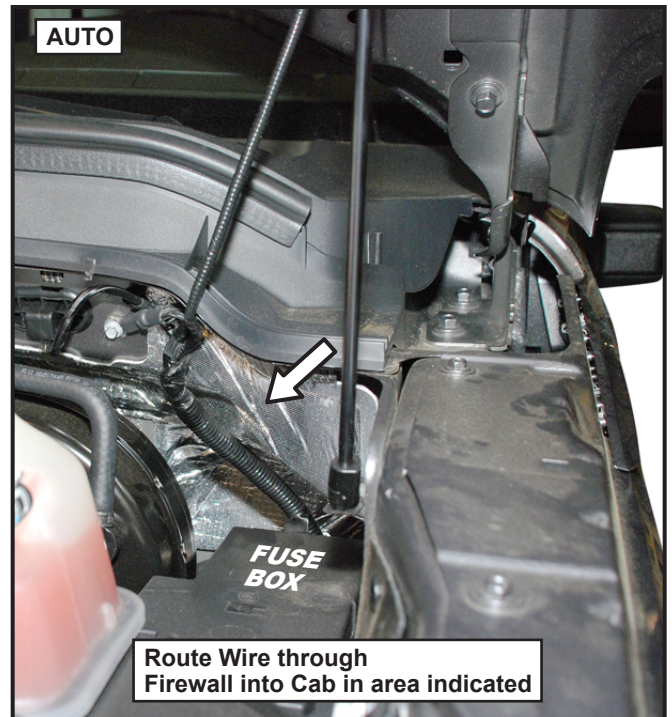
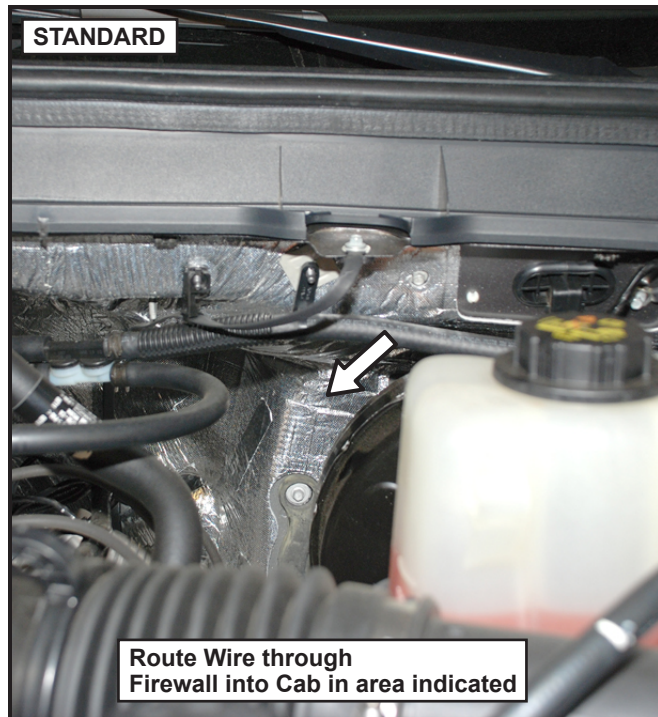

Figure 4. Routing Harness Wires after Mount Kit Installation



WARNING

It is highly recommended that front "helper springs", "airshocks", or other similar devices be installed onto this vehicle to prevent the front suspension from "bottoming out" while carrying a snow plow.

Vehicle must be properly "ballasted" by placing ballast weight behind the centerline of Rear Axle so that no more than 62% of the total weight of the Vehicle, Snow Plow, Driver, Ballast weight, (and any cargo) is placed on the Front Axle while at the same timenot exceeding the Gross Vehicle Weight Rating and Front or Rear Gross Axle Weight Ratings.

1FK42: 2008-2011 Ford Super Duty

Mounting Kit Installation Instructions

1. VEHICLE PREPARATION

- (1a.) Temporarily remove Hood Latch Operating Lever (behind Radiator Grill on 2008-2010 model years). Remove vehicle Front Bumper and Tow Hooks. Remove Frame Brackets (shown in Fig. 3). Save all fasteners for reuse.
- (1b.) Screw a 5/8"-11 Hex Jam Nut (12) all the way onto each of the 5/8"-11 x 3" Carriage Bolts (10). Place each Carriage bolt/Jam nut assembly through the ears on the Drivers and Passenger's side Push Arms (2) & (3) with the heads of the Carriage bolts to the front of the vehicle. Fasten loosely using a 5/8" Lock Washer (11) and 5/8"-11 Jam Nut on each Carriage bolt / Jam nut assembly.
- (1c.) Trim out portion of Lower plastic Air Dam below the Front Bumper 33" long (on center) and approximately 2" down from metal edge shown in Figure 1.
- (1d.) Remove and save the two 10mm nuts holding the 'U' shaped Sway Bar Clamp Bracket to each Frame Rail. Lower the Sway Bar and Brackets away from the Frame Rails.



NOTE

All fasteners should remain loose or "finger tight" until all components have been attached to Vehicle or installation instructions specify tightening.

• VEHICLES WITH DIESEL ENGINES ONLY

Loosen Clamps on Intercooler Tube Coupling inside Drivers Side Frame just behind Intercooler Radiator. Temporarily remove the Rubber Coupling and swing the steel tube back slightly to gain access to the inner surface of the Frame Rail. Intercooler tube and coupling can be reinstalled after mounting installation is complete.

IF EQUIPPED WITH OPTIONAL COOLER ON PASSENGER'S SIDE FRAME RAIL

Remove the two mounting bolts at top of Cooler. Retain hardware to be reinstalled after installation. Move Cooler away from Frame Rail to position Mounting Frame.

2. MOUNTING FRAME INSTALL

- (2a.) Place Drivers Side Push Arm (2) onto the inner surface of Drivers Side Frame Rail with the Horizontal Bolting Plate lined up with the Tow Hook bolt Holes in the top surface and the front slotted hole lined up with the hole in the inner surface of the Frame Rail. Swing the rear of the Push Arm up until the rear hole lines up with the slotted hole in the Frame Rail. Insert a 5/8"-11 x 1-1/2" Strap Bolt (4) from inside the Frame Rail through the slotted hole in the Rail and through the rear hole in the Push Arm. Fasten using a 5/8" Lock Washer (11) and 5/8"-11 Hex Nut (12).
- (2b.) Attach the Push Arm at the front slotted hole using a 1/2"-13 x 1-1/2" Bolt (6), 1/2" Flat Washer (9), 1/2" Lock Washer (7), and 1/2"-13 Hex Nut (8). Place the Drivers side Tow Hook on top of the Push Arm Horizontal Bolting Plate with the holes lined up with the holes in the Bolting Plate and Frame Rail. Fasten using the original equipment Tow Hook fasteners. Tighten all fasteners only enough to locate and seat the Push Arm as a guide, drill an 11/16" dia. hole through the inner surface of the Frame Rail. Fasten using a 5/8"-11 x 1-5/8" Strap Bolt (4), 5/8" Lock Washer (11), and 5/8"-11 Hex Nut (13). Loosen all fasteners holding the Push Arm to the Frame Rail.

• VEHICLES WITH DIESEL ENGINES ONLY

- Reinstall the Intercooling coupling and Clamps back onto the Intercooler Radiator and Tube. Tighten the Clamps fully.
- (2c.) Install the Passengers Side Push Arm (3) in the same sequence with the same amount and type of fasteners as Drivers side Push Arm (2).
- (2d.) Lift Mounting Frame (1) up under the front of the vehicle with the end plates of the cross tubes between the Push Arms (2) & (3). Line up the holes in the end plates of the cross tubes with the holes in the push arms and attach using 5/8"-11 x 2" Bolts (5), 5/8" Lock Washers (11), and 5/8"-11 Hex Nuts (13). Swing the sway bar and Brackets back up and fasten onto Frame Rails using the original equipment fasteners.

• VEHICLES WITH DIESEL ENGINES ONLY IF EQUIPPED WITH OPTIONAL COOLER ON PASSENGER'S SIDE FRAME RAIL

Remount the Cooler to Frame Rail using original equipment mounting hardware.

3. TIGHTENING

With Mounting Frame in final mounting position, fully tighten all Fasteners holding Mounting Frame (1) to Frame. Cut off excess metal from Strap Nuts.

4. FINAL ASSEMBLY AND INSPECTION

- (4a.) Reinstall the vehicle Front Bumper and Hood Release Operating Lever Bracket (if mounting on a 2008-2010 model year) using the original equipment fasteners. Align the Bumper and tighten.
- (4b.) Retain removed Frame Brackets (Step 1a.) with vehicle for reinstallation if Mounting Frame is ever removed.
- (4c.) Inspect all Mounting Frame (1) Attachment Bolts to be certain that all Bolts are in position and fully tightened.

5. OPTIONAL PLUG MOUNT BRACKET INSTALL



NOTE

Install the Plug Mount Bracket if the harness will be mounted on the frame kit, otherwise, the harness may be routed through the grill, bumper, etc.

Using (2) 10-32 x 3/4" hex bolts and nylon locknuts, fasten the Plug Mount Bracket to the Plug Mount Bracket Mounting Tab located on the drivers side of the frame kit receiver. The included 8-32 hardware is used for mounting the hi-amp battery leads to the Plug Mount Bracket, if used.

