



# **SNO-PRO<sup>®</sup> 3000**

**2009 - Ford F-150 4WD  
(With Snow Prep. Package ONLY)**

**Vehicle Mounting Kit: 1FK45A**

*Revised 12 June 2015*

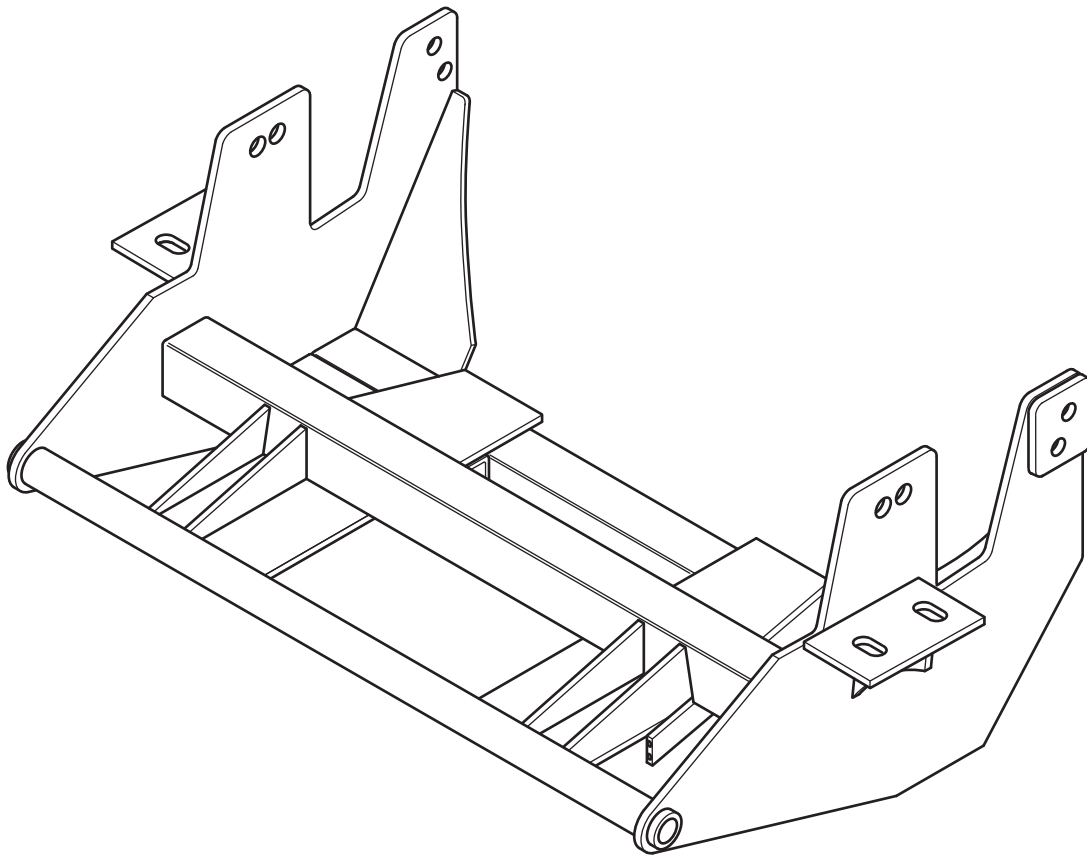

Curtis Industries LLC, 111 Higgins St., Worcester, MA 01606 TEL: (508) 853-2200 FAX: (508) 854-3377 For Parts and information visit us at [www.CurtisCab.com](http://www.CurtisCab.com)

Curtis Industries LLC, reserves the right to change product design or specifications without notice or liability.

Curtis Snow Plows are protected by the following U.S. Patent Numbers: 6,145,222 and 6,209,231 Licensed under U.S. Patent Number 5,568,694 & Canadian Patent Number 2,137,853.

Other patents pending.

## 1FK45A Vehicle Mount Kit Parts List

Item #	Description	Qty.
1	Mounting Frame	1
<b>Hardware Bag Components Included In This Kit</b>		
2	1/2"-13 Strap Bolt	2
3	1/2"-13 Hex Nut, Cad., Plated	2
4	1/2" Lock Washer	2
5	5/8"-11 Strap Bolt	2
6	5/8"-11 Hex Nut, Cad., Plated	2
7	5/8" Lock Washer, Cad., Plated	2
<b>Hardware Components Included In Plow Kit</b>		
1a	Dual Plug Harness Bracket	1
-	10-32 x 3/4" Hex Head Screw, Plated	2
-	10-32 Nylock Lock Nut, Plated	2
-	8-32 x 1" Hex Head Screw, Plated	1
-	8-32 Nylock Lock Nut, Plated	1
-	#8 Nylon Flat Washer, 3/4" O.D.	1
-	#8 Flat Washer, SAE, Plated	1

**Figure 1. Lower Bumper / Splash Shield Modification**

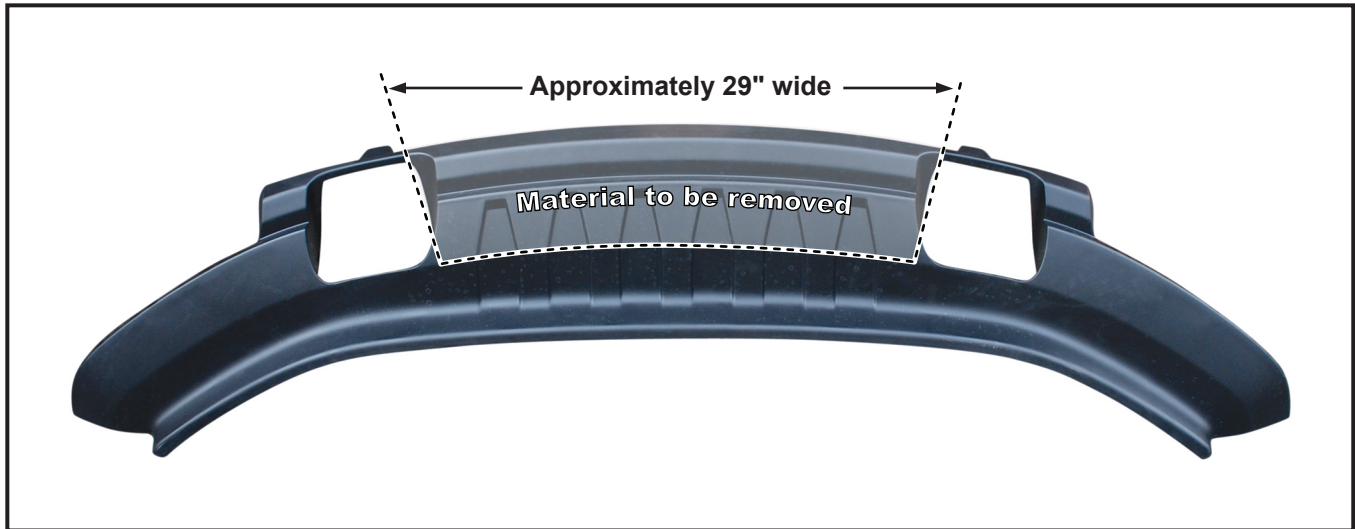

**WARNING**

It is highly recommended that front “helper springs”, “airshocks”, or other similar devices be installed onto this vehicle to prevent the front suspension from “bottoming out” while carrying a snow plow.

Vehicle must be properly “ballasted” by placing ballast weight behind the centerline of Rear Axle so that no more than 62% of the total weight of the Vehicle, Snow Plow, Driver, Ballast weight, (and any cargo) is placed on the Front Axle while at the same time not exceeding the Gross Vehicle Weight Rating and Front or Rear Gross Axle Weight Ratings.

# 1FK45A Mounting

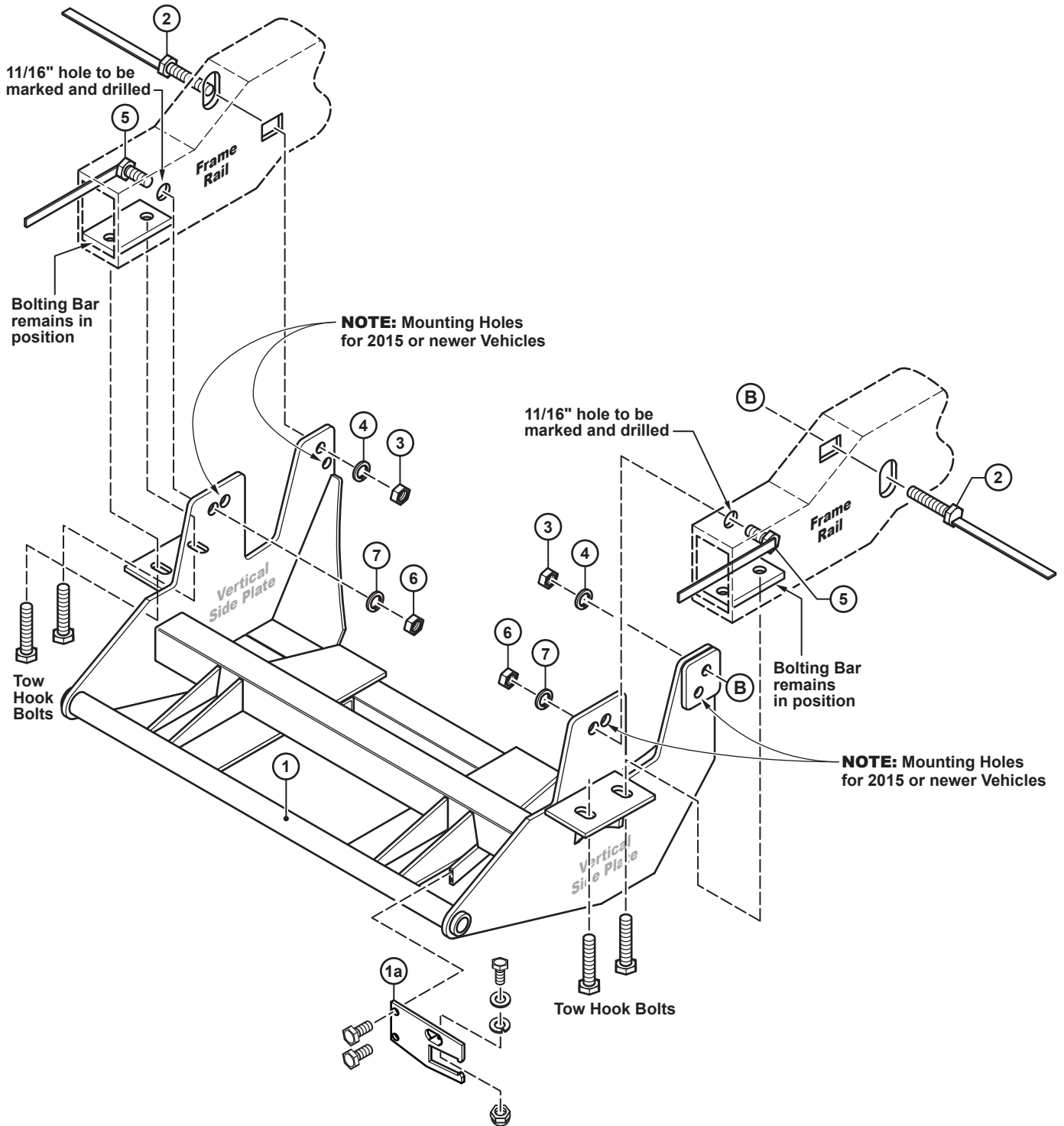

Curtis Industries, LLC. reserves the right to change product design or specifications without notice or liability. Curtis Snow Plows and Truck equipment should only be used on vehicles equipped with the manufacturer's Snow Plow preparation package. Snow Plowing without the original snow plow preparation package may damage your vehicle and the added weight of the equipment may impair the operation and control of the vehicle.

# 1FK45A: 2006 - Ford F-150 4WD

## Mounting Kit Installation Instructions

### 1. VEHICLE PREPARATION

- (1a.) Remove and store vehicle (front) tow hooks. Threaded tow hook bolting bars will remain in position inside Frame Rails. Retain all of the Tow Hook mounting bolts. Tow Hooks will not be reinstalled with Mounting Frame (1) mounted in position. Original equipment Tow Hook bolts and Bolting bars will be reused to install Mounting Frame (1).
- (1b.) Trim out portion of Lower plastic section of the Front Bumper 32" long and 8" high (refer to Figure 1).

### 2. MOUNTING FRAME

- (2a.) Lift Mounting Frame (1) up under front of Vehicle with Vertical Side Plates between inner walls of Frame Rails and with Horizontal bolting plates against the bottom walls of Frame Rails.
- (2b.) Line up holes in Horizontal bolting plates of Mounting Frame (1) with Tow Hook Bolt holes in Frame Rails. Fasten loosely using original equipment Tow Hook bolts threaded into Bolting bars inside Frame Rails. Insert one 1/2" Strap Bolt (2) through oblong hole on out side of Frame Rail and into square hole in Inner Frame Rail. Strap must be bent by hand 90 degrees to allow it to fit through the oblong hole. Fasten loosely using 1/2" Lock Washer (4) and 1/2" Hex Nut (3).



#### NOTE

All fasteners should remain loose or "finger tight" until all components have been attached to Vehicle or installation instructions specify tightening.

- (2c.) Using holes in Vertical Side Plates as guides, position Mounting Frame and drill two 11/16" mounting holes (1 per side) through inner flange of Frame Rail.
- (2d.) Insert a 5/8"-11 Strap Bolt (5) through the front of Frame Rail. Fasten loosely using 5/8" Lock Washer (7) and 5/8"-11 Hex Nut (6). Repeat same steps on opposite side of Mounting Frame.

### 3. TIGHTENING

With Mounting Frame in final mounting position, fully tighten all fasteners holding Mounting Frame to Frame Rails. Cut off excess metal from Strap Bolts.

### 4. FINAL ADJUSTMENT AND INSPECTION

- (4a.) Retain removed Tow Hooks with vehicle for reinstallation if Mounting Frame is removed from vehicle.
- (4b.) Inspect all Mounting Frame Attachment Bolts to be certain that all eight bolts are in position and fully tightened.

### 5. OPTIONAL PLUG MOUNT BRACKET INSTALL



#### NOTE

Install the Plug Mount Bracket if the harness will be mounted on the frame kit, otherwise, the harness may be routed through the grill, bumper, etc.

Using (2) 10-32 x 3/4" hex bolts and nylon locknuts, fasten the Plug Mount Bracket to the Plug Mount Bracket Mounting Tab located on the driver's side of the frame kit receiver. The included 8-32 hardware is used for mounting the hi-amp battery leads to the Plug Mount Bracket, if used.