

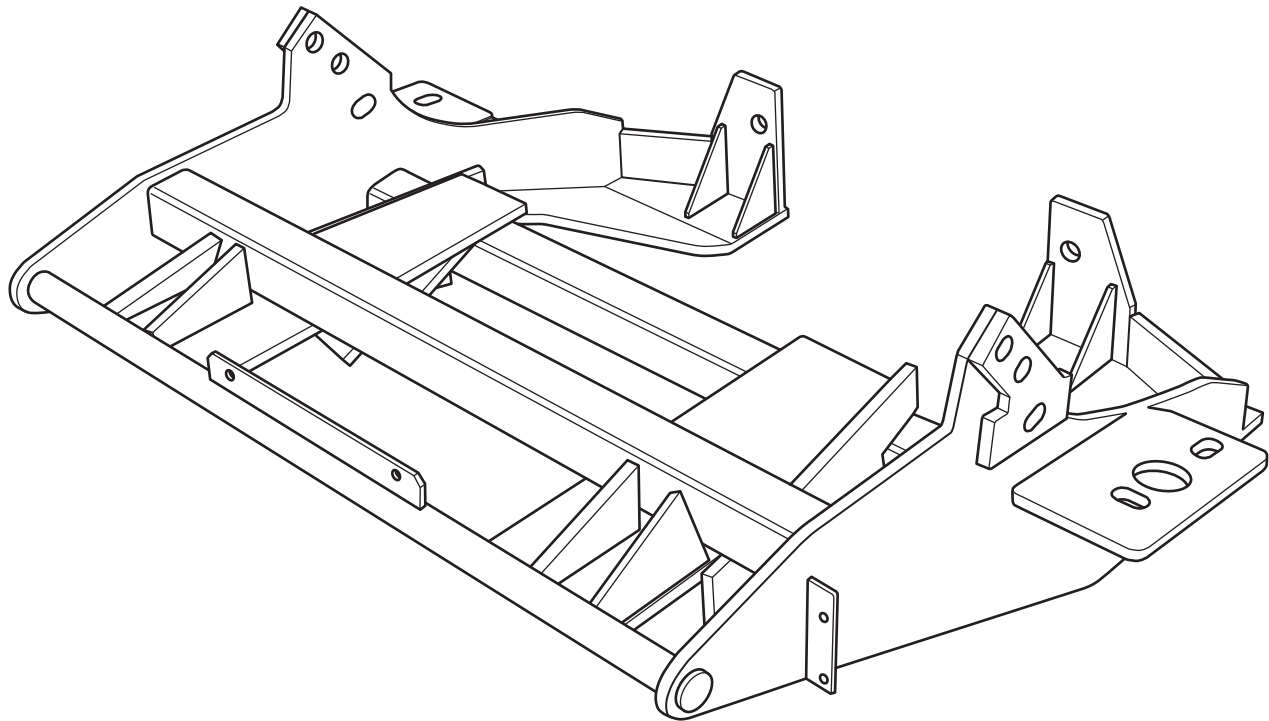

SNO-PRO[®] 3000

**2011 - GM Silverado / Sierra 2500, 3500
New Style (With Snow Plow Prep. ONLY)**

Vehicle Mounting Kit: 1FK47



Revised 17 May 2011

Curtis Industries Inc. LLC, 111 Higgins St., Worcester, MA 01606 TEL: (800) 343-7676 FAX: (508) 854-3377 For Parts and information visit us at www.Curtisindustries.net
Curtis Industries Inc. LLC, reserves the right to change product design or specifications without notice or liability.
Curtis Snow Plows are protected by the following U.S. Patent Numbers: 6,145,222 and 6,209,231 Licensed under U.S. Patent Number 5,568,694 & Canadian Patent Number 2,137,853.
Other patents pending.

1FK47 Vehicle Mount Kit Parts List

Item #	Description	Qty.
1	Mounting Frame	1
2	1/2"-13 x 1-1/2" Strap Bolt	2
3	Cross Member Spacer	2
24	Spacer Bar (Use only as needed with certain vehicle applications)	2
25	Shim Plate (Use only as needed with certain vehicle applications)	2
Hardware Bag Components Included In This Kit		
4	14mm-2.0 x 140mm Bolt, Gr.10.9, Plated	4
5	12mm-1.75 x 140mm Bolt, Gr.10.9, Plated	2
6	12mm-1.75 x 55mm Bolt, Gr.10.9, Plated	2
7	14mm Flat Washer, Plated	8
8	14mm Lock Washer, High Strength, Plated	4
9	14mm-2.0 Hex Nut, Plated	4
10	12mm Flat Washer, Plated	6
11	12mm Lock Washer, High Strength, Plated	4
12	12mm-1.75 Hex Nut, Plated	2
13	1/2" Flat Washer, Plated	2
14	1/2" Lock Washer, High Strength, Plated	2
15	1/2"-13 Hex Nut, Plated	2
16	5/8" x 5-1/2" Bolt, Gr. 5, Plated	2
17	5/8" Flat Washer, Plated	4
18	5/8" Lock Washer, High Strength, Plated	2
19	5/8" Hex Nut, Plated	2
20	1/4"-20 x 3/4" Bolt, Gr.5, Plated	2
21	1/4" Flat Washer, Plated	2
22	1/4" Lock Washer, High Strength, Plated	2
23	1/4"-20 Hex Nut, Plated	2
Hardware Components Included In Plow Kit		
1a	Dual Plug Harness Bracket	1
-	10-32 x 3/4" Hex Head Screw, Plated	2
-	10-32 Nylock Lock Nut, Plated	2
-	8-32 x 1" Hex Head Screw, Plated	1
-	8-32 Nylock Lock Nut, Plated	1
-	#8 Nylon Flat Washer, 3/4" O.D.	1
-	#8 Flat Washer, SAE, Plated	1



WARNING

It is highly recommended that front "helper springs", "airshocks", or other similar devices be installed onto this vehicle to prevent the front suspension from "bottoming out" while carrying a snow plow.

Vehicle must be properly "ballasted" by placing ballast weight behind the centerline of Rear Axle so that no more than 62% of the total weight of the Vehicle, Snow Plow, Driver, Ballast weight, (and any cargo) is placed on the Front Axle while at the same timenot exceeding the Gross Vehicle Weight Rating and Front or Rear Gross Axle Weight Ratings.

1FK47 Mounting

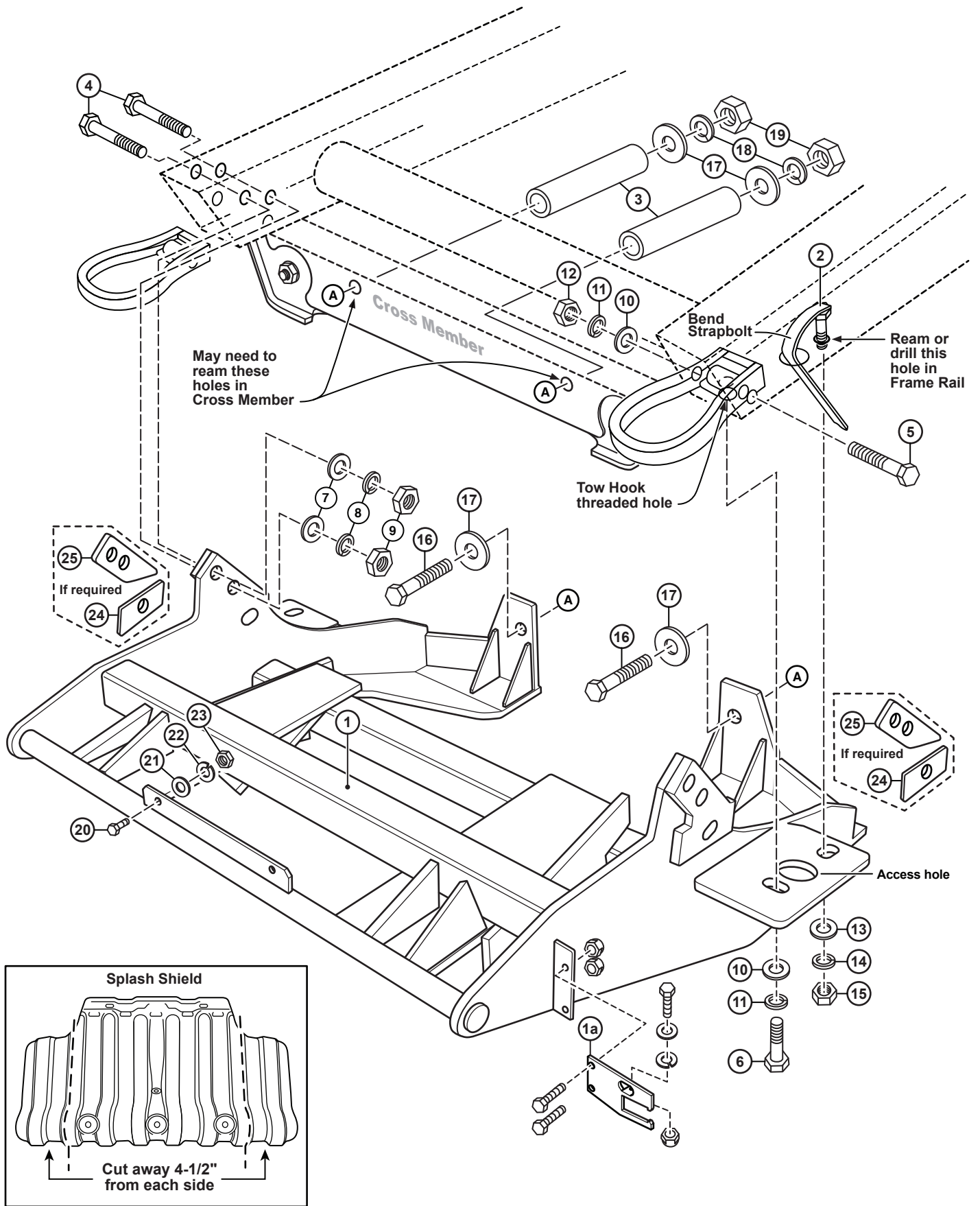

Curtis Industries, LLC. reserves the right to change product design or specifications without notice or liability. Curtis Snow Plows and Truck equipment should only be used on vehicles equipped with the manufacturer's Snow Plow preparation package. Snow Plowing without the original snow plow preparation package may damage your vehicle and the added weight of the equipment may impair the operation and control of the vehicle.

1FK47: 2011 - GM Silverado / Sierra 2500, 3500 New Style

Figure 1. Lower Bumper Trim

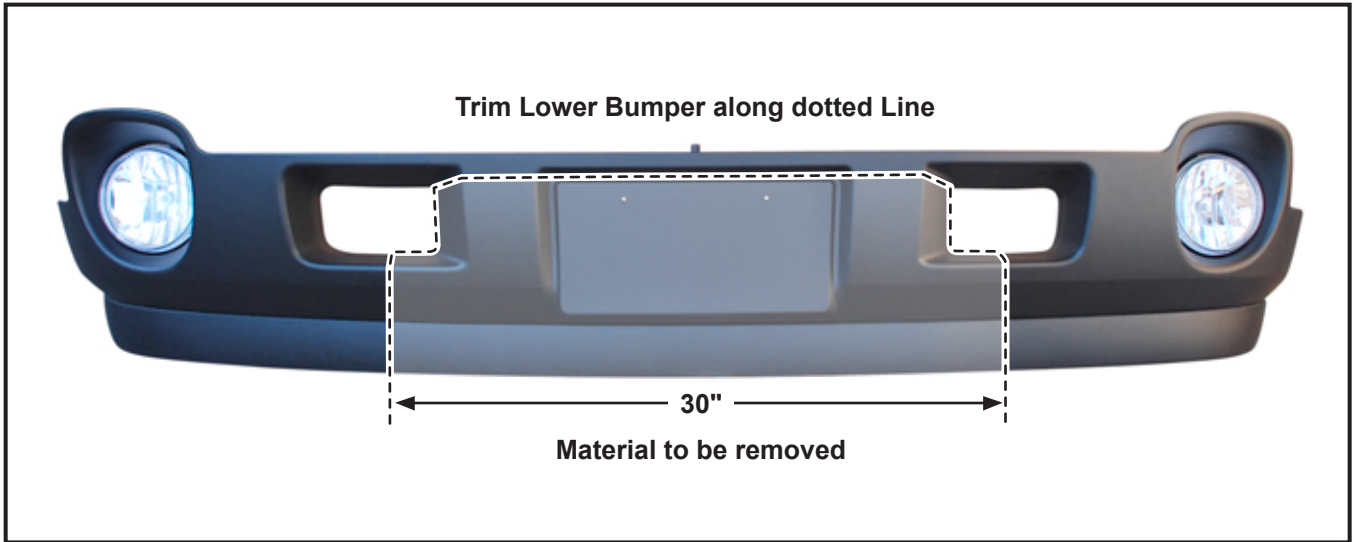

Figure 2. Frame Kit Mounting



Mounting Kit Installation Instructions

1. VEHICLE PREPARATION

- (1a.) Trim out an approximately 30" long section from the center of the lower plastic bumper / air dam.
- (1b.) Remove the plastic splash shield attached to the front suspension cross member and front cross tube member. Save the fasteners for reinstallation. Trim approximately 4-1/2" from each side of the splash shield.
- (1c.) Remove the two horizontal 14mm bolts and nuts holding the front bumper brackets to each frame rail. Remove the tow hook fasteners and tow hooks. The original equipment bumper bracket and tow hook fasteners will not be reused with the plow mount.



NOTE

All fasteners should remain loose or "finger tight" until all components have been attached to Vehicle or installation instructions specify tightening.

2. MOUNTING FRAME

- (2a.) Lift the mounting frame (1) up under the front of the vehicle between the frame rails with the upper front mounting holes in the side plates lined up with the holes in the bumper brackets and rails. With bumper bolts in mounting frame, ream cross member to fit the cross member spacer. Insert 5/8" x 5-1/2" bolt (16) with 5/8" flat washer (17) into the cross member spacer (3), through the cross member and rear mount holes. Secure with a 5/8" flat washer (17), 5/8" lock washer (18), and 5/8" Nut (19).
- (2b.) Fasten the side plates of the mounting frame (1) to the front of the frame rails and bumper brackets using 14mm-2.0 x 140mm bolts (4), 14mm flat washers (7), 14mm lock washers (8), and 14mm-2.0 nuts (9). Insert the tow hooks back into the frame rails and fasten using a 12mm-1.75 x 55mm bolt (6), 12mm lock washer (11) and 12mm flat washer (10) up through the front slotted hole in each horizontal bolting plate of the mounting frame (1), the bottom surface of each frame rail, and thread into the tow hooks.
- (2c.) Fasten the lower front hole of the side plates of the mounting frame (1) to the inner surface of the frame rails, through the horizontal hole in the tow hooks and frame rail outer surfaces using 12mm-1.75 x 140mm. bolts (5), 12mm flat washers (10), 12mm lock washers (11), and 12mm-1.75 nuts (12). Spacer Bars (24) and Shim Plates (25) are provided in Hardware Kit if needed to attain a correct fit. Tighten all installed mounting frame, bumper bracket, and tow hook fasteners at this time.
- (2d.) Using the rear slotted holes in each horizontal bolting plate of the mounting frame (1) as guides, ream or drill out the holes in the bottom surface of the frame rails to 9/16" diameter. Insert 1/2"-13 x 1-1/2" strap bolts (2) up through the large diameter holes in the horizontal bolting plates and frame rail and back down through the reamed holes. (straps on the strap bolts (2) can easily be bent and shaped to fit). Fasten and tighten the strap bolts (2) using 1/2" flat washers (13), 1/2" lock washers (14) and 1/2"-13 nuts (15). Trim the strap bolt straps even with the frame rails.

3. FINAL ADJUSTMENT AND INSPECTION

- (3a.) Reinstall the trimmed plastic splash shield back in its original position using the original equipment fasteners. The front license plate can be mounted to the bracket on the round bar of the mounting frame using 1/4"-20 x 3/4" bolts (20), 1/4" flat washers (21), 1/4" lock washers (22), and 1/4"-20 nuts (23).
- (3b.) Inspect the mounting attachment and original equipment bolts to be certain that they are all in place and that they are all tight.

4. OPTIONAL PLUG MOUNT BRACKET INSTALL



NOTE

Install the Plug Mount Bracket if the harness will be mounted on the frame kit, otherwise, the harness may be routed through the grill, bumper, etc.

Using (2) 10-32 x 3/4" hex bolts and nylon locknuts, fasten the Plug Mount Bracket to the Plug Mount Bracket Mounting Tab located on the drivers side of the frame kit receiver. The included 8-32 hardware is used for mounting the hi-amp battery leads to the Plug Mount Bracket, if used.

