



SNO-PRO[®] 3000

**1999 – 2004 Ford Super Duty F-250, F-350
(4 x 4 With 86M Option ONLY)**

Vehicle Mounting Kit: 1FK5D

Revised 14 February 2011

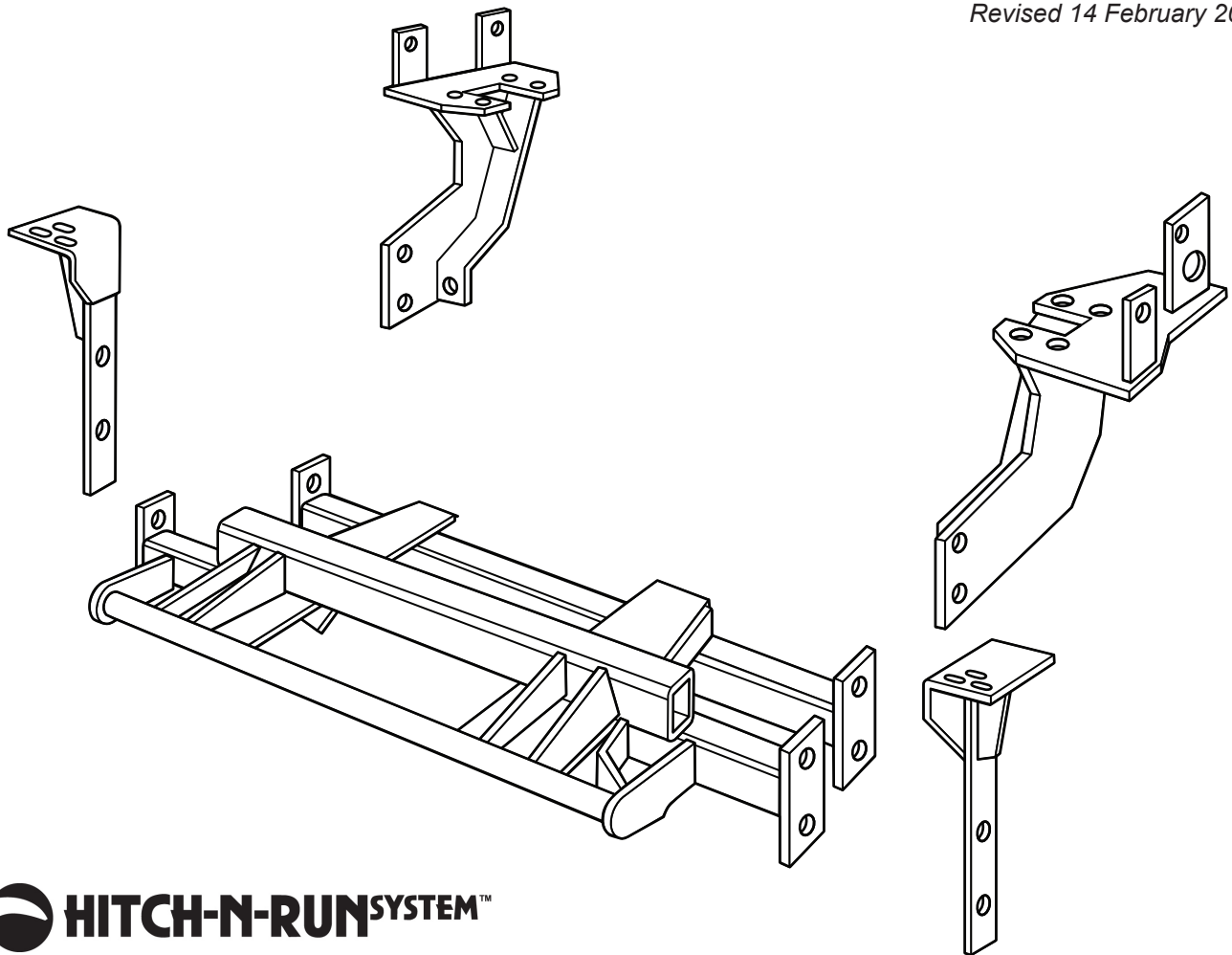

Curtis Industries Inc. LLC, 111 Higgins St., Worcester, MA 01606 TEL: (800) 343-7676 FAX: (508) 854-3377 For Parts and information visit us at www.Curtisindustries.net
Curtis Industries Inc. LLC, reserves the right to change product design or specifications without notice or liability.
Curtis Snow Plows are protected by the following U.S. Patent Numbers: 6,145,222 and 6,209,231 Licensed under U.S. Patent Number 5,568,694 & Canadian Patent Number 2,137,853.
Other patents pending.

1FK5D Vehicle Mount Kit Parts List

Item #	Description	Qty.
1	Driver's Side Front Hanger	1
2	Passenger's Side Front Hanger	1
3	Mounting Frame	1
4	Driver's Side Push Arm	1
5	Passenger's Side Push Arm	1
8	1/2"-13 x 1-1/2" Bolt, Gr. 5, W/ Strap	8
Hardware Bag Components Included In This Kit		
6	1/2"-13 x 1-1/2" Bolt, Gr. 5, Cad., Plated	8
7	1/2"-13 x 2" Bolt, Gr. 5, Cad., Plated	4
9	1/2" Lockwasher	16
10	1/2" Flatwasher	8
11	1/2"-13 Hex Nut	16
12	5/8"-11 x 2-1/2" Carriage Bolt, Gr. 5, Cad., Plated	2
13	5/8" Lockwasher, Cad., Plated	2
14	5/8"-11 Hex Jam Nut, Cad., Plated	4
Hardware Components Included In Plow Kit		
3a	Plug Mount Bracket	1
-	10-32 x 3/4" Hex Head Screw, Plated	2
-	10-32 Nylock Lock Nut, Plated	2
-	8-32 x 1" Hex Head Screw, Plated	1
-	8-32 Nylock Lock Nut, Plated	1
-	#8 Nylon Flat Washer, 3/4" O.D.	1
-	#8 Flat Washer, SAE, Plated	1



WARNING

It is highly recommended that front "helper springs", "airshocks", or other similar devices be installed onto this vehicle to prevent the front suspension from "bottoming out" while carrying a snow plow.

Vehicle must be properly "ballasted" by placing ballast weight behind the centerline of Rear Axle so that no more than 62% of the total weight of the Vehicle, Snow Plow, Driver, Ballast weight, (and any cargo) is placed on the Front Axle while at the same time not exceeding the Gross Vehicle Weight Rating and Front or Rear Gross Axle Weight Ratings.

1FK5D Mounting

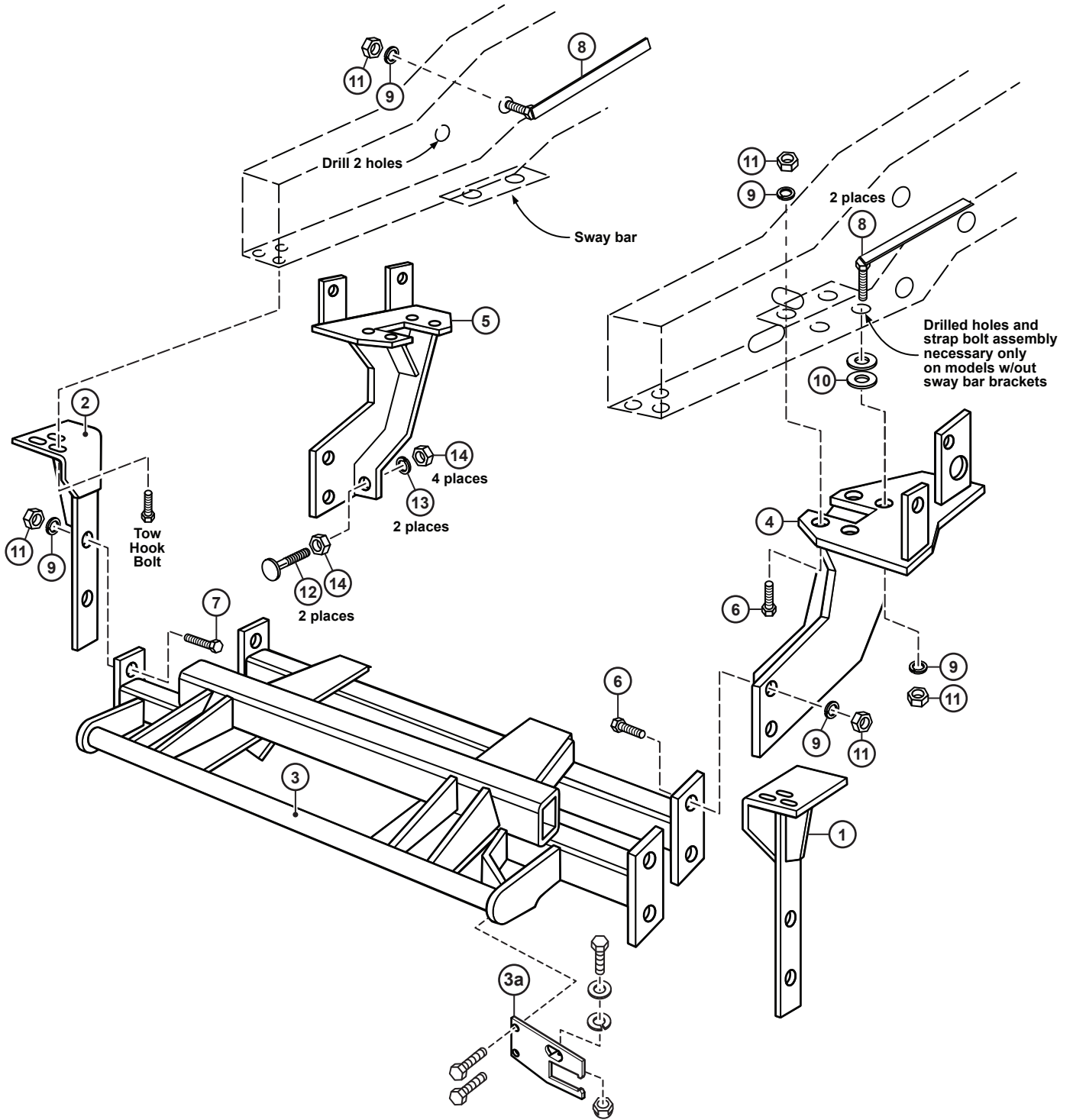

Curtis Industries, LLC. reserves the right to change product design or specifications without notice or liability. Curtis Snow Plows and Truck equipment should only be used on vehicles equipped with the manufacturer's Snow Plow preparation package. Snow Plowing without the original snow plow preparation package may damage your vehicle and the added weight of the equipment may impair the operation and control of the vehicle.

1FK5D: 1999 – 2004 Ford Super Duty F-250, F-350 4 x 4

Mounting Kit Installation Instructions

1. VEHICLE PREPARATION

- (1a.) Temporarily remove the vehicle front bumper and tow hooks. Save all bumper and tow hook fasteners for reuse.
- (1b.) Screw a 5/8"-11 hex jam nut (14) all the way onto each of the 5/8"-11 x 2-1/2" carriage bolts (12). Place each carriage bolt / jam nut assembly through the ears on the driver's side and passenger's side push arms (4) & (5) with the heads of the carriage bolts toward the front of the vehicle. Fasten loosely using a 5/8" lockwasher (13) and 5/8"-11 hex jam nut (14) on each carriage bolt / jam nut assembly.



NOTE

All fasteners should remain loose or "finger tight" until all components have been attached to vehicle or installation instructions specify tightening.

- (1c.) Jack vehicle up from under the frame rails until front wheels clear the ground. Place jack stands under the frame rails to the rear of the front wheels to prevent unintended lowering of the vehicle.

2. FRONT HANGERS

Line up the three slotted holes in each front hanger (1) & (2) with the tow hook holes in the lower flange of each frame rail. Attach using the original equipment tow hook bolts up through the front hangers, through the holes in the lower flange of the frame rails, and threaded into the holes in the tow hooks.

3. MOUNTING FRAME

Lift the Mounting frame (3) up under the front of the vehicle with the end plates of the front cross tube between the vertical bars of the front hangers (1) & (2). Line up the holes in the end plates of the cross tube with the holes in the vertical bars of the front hangers and attach using 1/2"-13 x 2" bolts (6), 1/2" lockwashers (9), and 1/2"-13 hex nuts (11).

4. DRIVER'S SIDE PUSH ARM

- (4a.) Turn the steering wheel all the way to the right. From between the frame rails, place the upper end of the driver's side push arm (4) between the spring and the lower flange of the frame rail.
- (4b.) **FOR VEHICLES THAT HAVE SWAY BAR BRACKETS WELDED TO FRAME:** Line up the two inner holes in the horizontal plate of the push arm with the two holes in the sway bar bracket. Attach using 1/2"-13 x 1-1/2" bolts (8), 1/2" lockwashers (9), and 1/2"-13 nuts (11).
- (4c.) **FOR VEHICLES THAT DO NOT HAVE SWAY BAR BRACKETS WELDED TO FRAME:** Two 1/2" holes will have to be drilled in the bottom flange of each frame rail at a later step in the installation.
- (4d.) **ALL VEHICLES:** Line up the two holes in the front end of the Driver's side push arm (4) with the holes in the end plate of the rear cross tube of the mounting frame (3). Fasten using 1/2"-13 x 1-1/2" bolts (6), 1/2" lockwashers (9), and 1/2"-13 nuts (11).

5. PASSENGER'S SIDE PUSH ARM

Turn the steering wheel to the left until the wheels are centered. Install the passenger's side push arm (5) in the same sequence and with the same amount and type of fasteners as the driver's side push arm (4).

6. DRILLING AND TIGHTENING

- (6a.) Tighten the tow hook bolts and the 1/2" fasteners holding the mounting frame (3) to the front hangers (1) & (2).

- (6b.) **FOR VEHICLES THAT HAVE SWAY BAR BRACKETS WELDED TO FRAME:** Tighten the 1/2" fasteners holding horizontal plates of the push arms (4) & (5) to the sway bar brackets on the frame rails. Tighten the 1/2" fasteners holding the front ends of the push arms to the end plates of the rear cross tube on the mounting frame (3).

- (6c.) **FOR VEHICLES THAT DO NOT HAVE SWAY BAR BRACKETS WELDED TO FRAME:** Hold the horizontal plates of the of the push arms (4) & (5) up against the bottom flanges of the frame rails. Mark the bottom flange of each frame rail at the two outer hole locations in the horizontal plates of the push arms. Drill two 1/2" holes up through each frame rail. Attach and tighten each push arm to the bottom flange of each frame rail using two 1/2"-13 x 1-1/2" bolts w/strap (8) down through the each frame rail with two 1/2" flatwashers (10) between the frame rail and horizontal plate of the push arm on each bolt and with 1/2" lockwashers (9) and 1/2"-13 nuts (11) under the horizontal plates of the push arms (4) & (5).

- (6d.) **ALL VEHICLES:** Using the holes in the vertical ears of the push arms (4) & (5) as guides, drill two 1/2" holes through the outer flange of each frame rail. Attach and tighten each push arm to the outer flange of each frame rail using two 1/2"-13 x 1-1/2" bolts W/strap (8), 1/2" lockwashers (9), and 1/2"-13 nuts (11). Adjust the 5/8"-11 x 2-1/2" carriage bolts (12) with the front 5/8" jam nuts (14) so that the heads of the carriage bolts are tight against the back of the rear cross tube of the mounting frame (3). Lock the 5/8"-11 x 2-1/2" carriage bolts (12) in place using the rear 5/8"-11 jam nuts (14).

7. FINAL ADJUSTMENT AND INSPECTION

- (7a.) Reinstall the vehicle front bumper using the original equipment fasteners.
- (7b.) Inspect the mounting attachment bolts to be certain that they are all in place and that they are all tight. Remove the jack stands from under frame rails and lower vehicle to the ground.

8. OPTIONAL PLUG MOUNT BRACKET INSTALL



NOTE

Install the Plug Mount Bracket if the harness will be mounted on the frame kit, otherwise, the harness may be routed through the grill, bumper, etc.

Using (2) 10-32 x 3/4" hex bolts and nylon locknuts, fasten the Plug Mount Bracket to the Plug Mount Bracket Mounting Tab located on the driver's side of the frame kit receiver. The included 8-32 hardware is used for mounting the hi-amp battery leads to the Plug Mount Bracket if used.

