

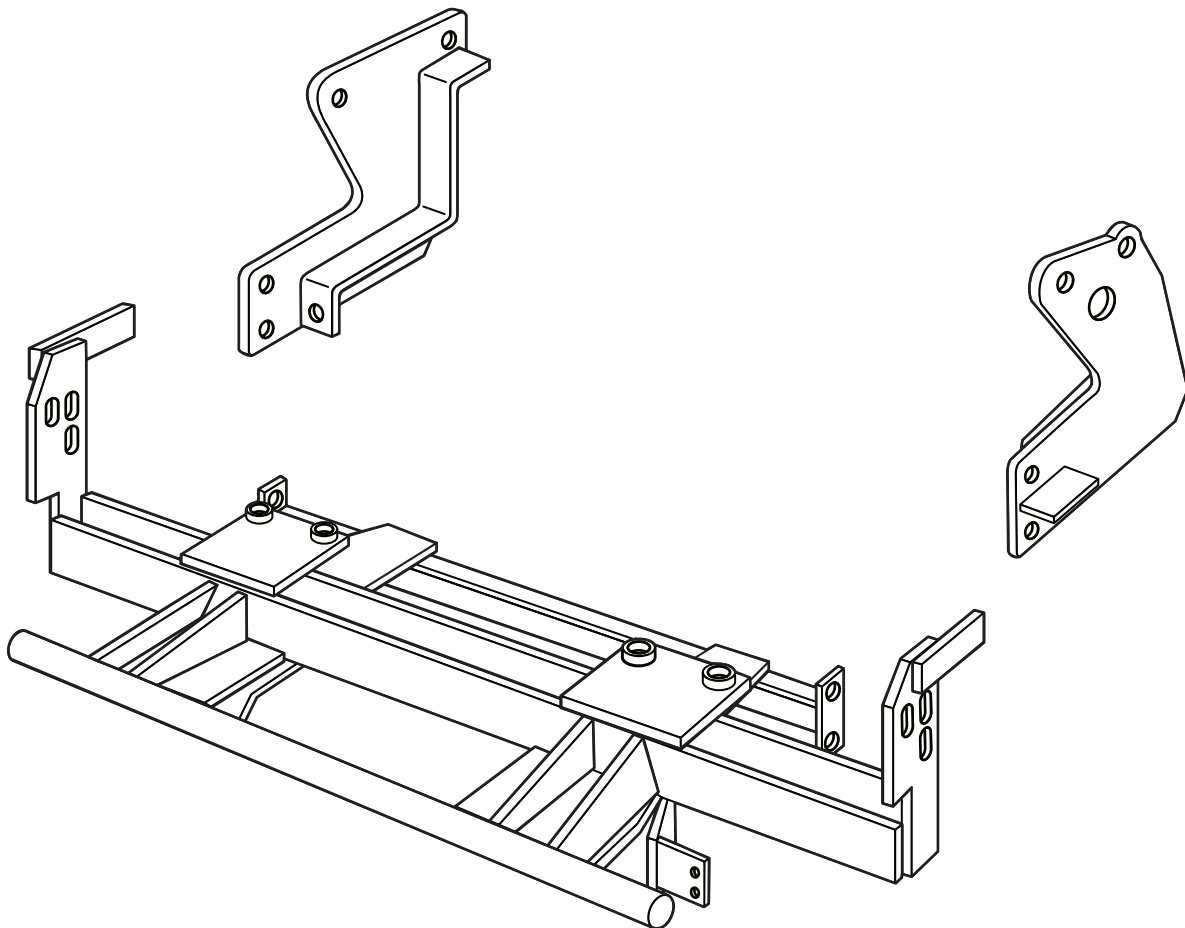

# SNO-PRO<sup>®</sup> 3000

**1994 – 2001 Dodge 1500 & 1994 – 2002 Dodge 2500, 3500  
(4 x 4 With Plow Prep. ONLY)**

## **Vehicle Mounting Kit: 1FK10C**



Revised 14 February 2011

Curtis Industries Inc. LLC, 111 Higgins St., Worcester, MA 01606 TEL: (800) 343-7676 FAX: (508) 854-3377 For Parts and information visit us at [www.Curtisindustries.net](http://www.Curtisindustries.net)  
Curtis Industries Inc. LLC, reserves the right to change product design or specifications without notice or liability.  
Curtis Snow Plows are protected by the following U.S. Patent Numbers: 6,145,222 and 6,209,231 Licensed under U.S. Patent Number 5,568,694 & Canadian Patent Number 2,137,853.  
Other patents pending.

## 1FK10C Vehicle Mount Kit Parts List

Item #	Description	Qty.
1	Mounting Frame	1
2	Driver's Side Push Arm	1
3	Passenger's Side Push Arm Plated	1
10	5/8"-11 x 1-1/2" Strap Bolt (12" Long)	3
<b>Hardware Bag Components Included In This Kit</b>		
4	1/2"-13 x 1-1/2" Bolt, Gr. 5, Cad., Plated	6
5	1/2"-13 x 1-3/4" Bolt, Gr. 5, Cad., Plated	4
6	1/2" Flatwasher Cad., Plated	8
7	1/2" Lockwasher, Cad., Plated	10
8	1/2"-13 Hex Nut, Cad., Plated	10
9	5/8"-11 x 4-1/2" Bolt, Gr. 5, Cad., Plated	1
11	5/8"-11 x 2-1/2" Carriage Bolt, Gr. 5, Cad., Plated	2
12	5/8" Lockwasher, Cad., Plated	6
13	5/8"-11 Hex Jam Nut, Cad., Plated	4
14	5/8"-11 Hex Nut, Cad., Plated	4
<b>Hardware Components Included In Plow Kit</b>		
1a	Plug Mount Bracket	1
-	10-32 x 3/4" Hex Head Screw, Plated	2
-	10-32 Nylock Lock Nut, Plated	2
-	8-32 x 1" Hex Head Screw, Plated	1
-	8-32 Nylock Lock Nut, Plated	1
-	#8 Nylon Flat Washer, 3/4" O.D.	1
-	#8 Flat Washer, SAE, Plated	1



### WARNING

It is highly recommended that front "helper springs", "airshocks", or other similar devices be installed onto this vehicle to prevent the front suspension from "bottoming out" while carrying a snow plow.

Vehicle must be properly "ballasted" by placing ballast weight behind the centerline of Rear Axle so that no more than 62% of the total weight of the Vehicle, Snow Plow, Driver, Ballast weight, (and any cargo) is placed on the Front Axle while at the same time not exceeding the Gross Vehicle Weight Rating and Front or Rear Gross Axle Weight Ratings.



# 1FK10C Mounting

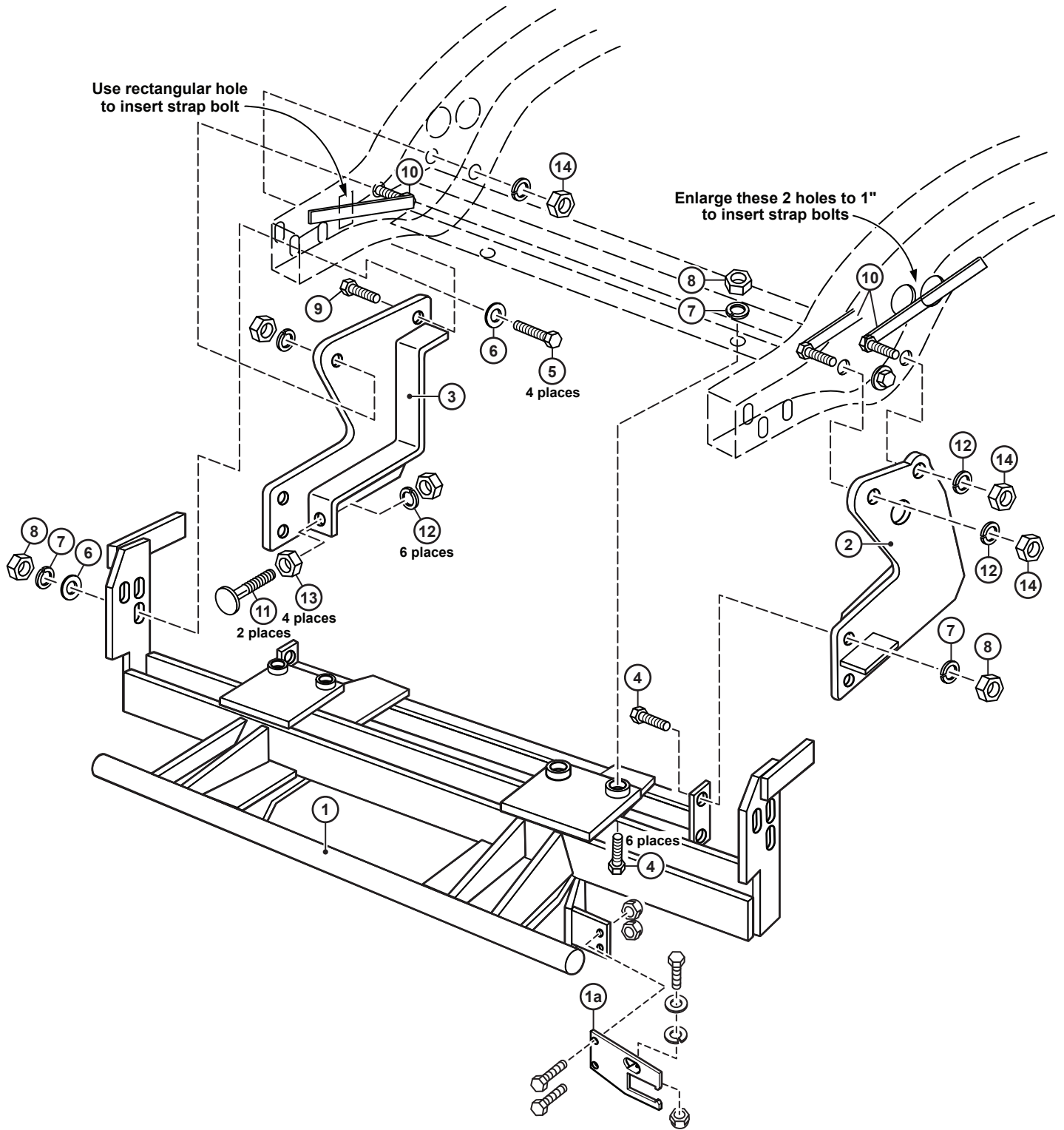

**Curtis Industries, LLC. reserves the right to change product design or specifications without notice or liability. Curtis Snow Plows and Truck equipment should only be used on vehicles equipped with the manufacturer's Snow Plow preparation package. Snow Plowing without the original snow plow preparation package may damage your vehicle and the added weight of the equipment may impair the operation and control of the vehicle.**

# 1FK10C: 1994 – 2001 Dodge 1500 and 1994 – 2002 Dodge 2500,3500

## Mounting Kit Installation Instructions

### 1. VEHICLE PREPARATION

- (1a.) Remove the fasteners holding the front bumper brackets to the frame rails. Discard the front two fasteners and nuts on each side. Save the rear fasteners and nuts for later reinstallation. Remove the bumper braces. Save the braces and fasteners for later reinstallation. Remove and set aside the front bumper.
- (1b.) Either remove the vehicle air dam (if so equipped) and fasteners or cut and remove a section 38" long out of the center of it.
- (1c.) On the driver's side frame rail, ream out the hole just behind the rear steering box bolt to 11/16" diameter. Also on the driver's side frame rail, enlarge the two (approx. 1" dia.) holes just ahead of the spring mount tower enough so that the 5/8"-11 x 1-1/2" strap bolts (10) will fit through them.
- (1d.) Screw a 5/8"-11 hex jam nut (13) all the way onto each of the 5/8"-11 x 2-1/2" carriage bolts (11). Place each carriage bolt/ jam nut assembly into the push ears of the rear push arm frames (2 & 3) with the heads of the carriage bolts toward the front of the vehicle. Fasten loosely using a 5/8"-11 hex jam nut (13) and 5/8" lock washer (12) on each carriage bolt / jam assembly.



#### NOTE

All fasteners should remain loose or "finger tight" until all components have been attached to vehicle or installation instructions specify tightening.

### 2. FRONT MOUNTING FRAME

- (2a.) Lift the mounting frame (1) up onto the front of the vehicle frame with the vertical ears outside of the frame rails and with two of the three slotted holes (depending on the year of the vehicle) in the vertical ears lined up with the two slotted holes in the frame rails that the front bumper bracket bolts were removed from.
- (2b.) Reinstall the vehicle bumper and brackets back onto the frame rails, then line up the two slotted holes on each side with the slotted holes in the rails and the ears of the mounting frame (1). Attach using two 1/2"-13 x 1-3/4" bolts (5), 1/2" flatwashers (6), 1/2" lockwashers (7), and 1/2"-13 hex nuts (8) through each bumper bracket, frame rail and vertical ear of the mounting frame (1).
- (2c.) Reinstall the original equipment rear bumper bracket fasteners and nuts back into the location that they were removed from earlier. Reinstall bumper braces back to their original location using the original equipment fasteners.
- (2d.) Line up two of the four holes in the horizontal ears on the cross bars of the mounting frame (1) with two holes (depending on the year of the vehicle) in the front cross member.



#### NOTE

These holes may have to be drilled or reamed out depending on the year and/or model of the vehicle.

Fasten using a 1/2"-13 x 1-1/2" bolt (4), 1/2" lockwasher (7), and 1/2"-13 hex nut (8) each hole.

### 3. DRIVER'S SIDE PUSH ARM

Install the rear section of the driver's side push arm (2) up between the sway bar and the outside surface of the frame rail with the large clearance hole in the push arm on over the rear steering box bolt and washer. Insert a 5/8"-11 x 1 1/2" strap bolt (10) into the frame rail from the lower large hole just ahead of the spring/shock tower. Place the threaded end of the strap bolt (10) out through the reamed out hole in the frame rail and the rear hole in the driver's side push arm. Fasten using a 5/8" lockwasher (12) and 5/8"-11 hex nut (14). Line up the holes in the front end of the push

arm (2) with the holes in the end plate of the rear cross tube on the mounting frame (1). Fasten using 1/2"-13 x 1-1/2" bolts (4), 1/2" lockwashers (7), and 1/2"-13 hex nuts (8).

### 4. PASSENGER'S SIDE PUSH ARM

Install the rear section of the passenger's side push arm (3) up between the sway bar and the outside surface of the frame rail with the rear hole in the push arm lined up with the lower hole just ahead of the spring/shock tower. Fasten using a 5/8"-11 x 4-1/2" bolt (9) through the push arm, and through both sides of the frame rail with a 5/8" lockwasher (12), and 5/8"-11 hex nut (14) on the inside surface. Line up the holes in the front end of the push arm (3) with the holes in the end plate of the rear cross tube on the mounting frame (1). Fasten using 1/2"-13 x 1-1/2" bolts (4), 1/2" lock washers (7), and 1/2"-13 hex nuts (8).

### 5. DRILLING & TIGHTENING

- (5a.) Tighten the two 1/2"-13 fasteners holding the mounting frame (1) to the vehicle front cross member. Tighten the four 1/2"-13 fasteners holding the front bumper brackets and mounting frame (1) to the frame rails. Tighten the bumper brace fasteners. Tighten the 5/8"-11 and 1/2"-13 fasteners holding the push arms (2 & 3) to the frame rails and mounting frame (1).
- (5b.) Using the remaining open hole in the drivers side push arm (2) as a guide, drill or ream out (if necessary) a 11/16" dia. hole in the outside surface of the frame rail. Insert a 5/8"-11 x 1-1/2" strap bolt (10) into the frame rail from the upper large hole just ahead of the spring /shock tower. Place the threaded end of the strap bolt (10) out through the reamed hole in the frame rail and the front hole in the push arm. Fasten and tighten using a 5/8" lockwasher (12) and 5/8"-11 hex nut (14).
- (5c.) Using the remaining open hole in the passenger's side push arm (3) as a guide, drill or ream out (if necessary) a 11/16" dia. hole in the outside surface of the frame rail. Insert a 5/8"-11 x 1-1/2" strap bolt (10) into the frame rail from the large rectangular hole where the bumper brace attaches. Place the threaded end of the strap bolt (10) out through the reamed hole in the frame rail and the front hole in the push arm (3). Fasten and tighten using a 5/8" lockwasher (12) and 5/8"-11 hex nut (14). Adjust the 5/8"-11 x 2-1/2" carriage bolts (11) with the front 5/8"-11 jam nuts (13) so that the heads of the carriage bolts are tight against the back of the rear cross tube of the front mounting frame (1). Lock the 5/8"-11 x 2-1/2" carriage bolts (11) in place using the rear 5/8"-11 jam nuts (13).

### 6. FINAL ADJUSTMENT AND INSPECTION

Check the front bumper to be certain that it is straight and aligned with the vehicle body work and grill. Inspect the mounting attachment bolts to be certain that they are all in place and that they are all tight.

### 7. OPTIONAL PLUG MOUNT BRACKET INSTALL



#### NOTE

Install the Plug Mount Bracket if the harness will be mounted on the frame kit, otherwise, the harness may be routed through the grill, bumper, etc.

Using (2) 10-32 x 3/4" hex bolts and nylon locknuts, fasten the Plug Mount Bracket to the Plug Mount Bracket Mounting Tab located on the driver's side of the frame kit receiver. The included 8-32 hardware is used for mounting the hi-amp battery leads to the Plug Mount Bracket if used.