



# SNO-PRO<sup>®</sup> 3000

**2003 – Dodge 2500, 3500 4WD  
(With Snow Plow Prep. ONLY)**

**Vehicle Mounting Kit: 1FK20**

*Revised 14 February 2011*

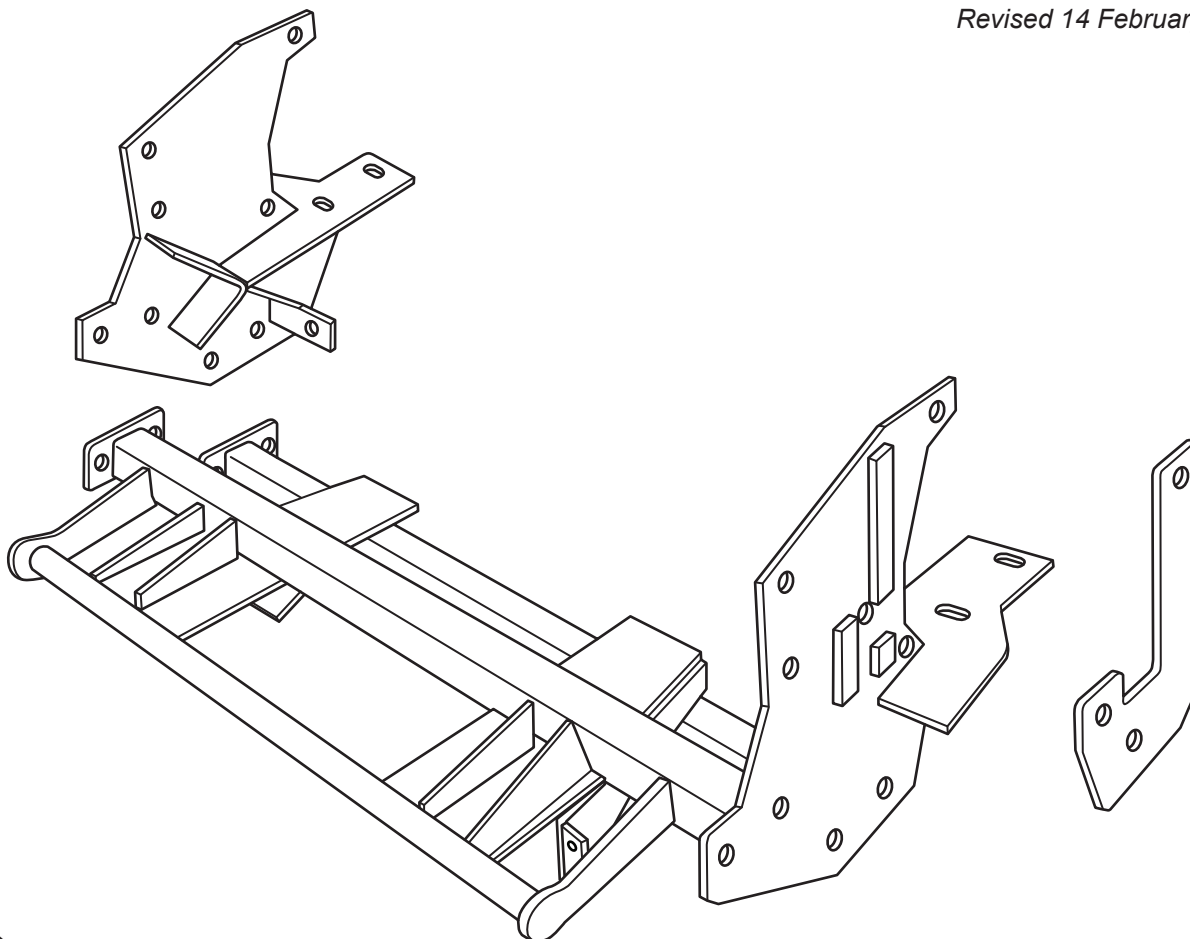

Curtis Industries Inc. LLC, 111 Higgins St., Worcester, MA 01606 TEL: (800) 343-7676 FAX: (508) 854-3377 For Parts and information visit us at [www.Curtisindustries.net](http://www.Curtisindustries.net)  
Curtis Industries Inc. LLC, reserves the right to change product design or specifications without notice or liability.  
Curtis Snow Plows are protected by the following U.S. Patent Numbers: 6,145,222 and 6,209,231 Licensed under U.S. Patent Number 5,568,694 & Canadian Patent Number 2,137,853.  
Other patents pending.

## 1FK20 Vehicle Mount Kit Parts List

Item #	Description	Qty.
1	Front Mount Frame	1
2	Driver's Side Push Arm	1
3	Passenger's Side Push Arm	1
4	Clamp Bar	2
5	Bumper Bracket Shim	2
6	Sway Bar Bracket Shim	2
<b>Hardware Bag Components Included In This Kit</b>		
7	1/2"-13 x 1-1/2" Bolt, Gr.5, Plated	8
8	1/2"-13 x 4 Bolt, Gr.5, Plated	6
9	1/2" Flat Washer, Plated	8
10	1/2" Lock Washer, High Strength, Plated	14
11	1/2"-13 Hex Nut, Plated	14
12	M10-1.5 x 40 MM Bolt, Gr.10.9, Plated	4
13	M10 Flat Washer, Plated	4
14	M10 Lock Washer, High Strength, Plated	4
15	M12-1.75 x 110 MM, Gr.10.9, Plated	4
16	M12 Flat Washer, Plated	4
17	M12 Lock Washer, High Strength, Plated	4
18	M12-1.75 Hex Nut, Plated	4
19	5/8"-11 x 2-1/2" Carriage Bolt, Gr.5, Plated	2
20	5/8" Lock Washer, High Strength, Plated	2
21	5/8"-11 Hex Jam Nut, Plated	4
<b>Hardware Components Included In Plow Kit</b>		
1a	Plug Mount Bracket	1
-	10-32 x 3/4" Hex Head Screw, Plated	2
-	10-32 Nylock Lock Nut, Plated	2
-	8-32 x 1" Hex Head Screw, Plated	1
-	8-32 Nylock Lock Nut, Plated	1
-	#8 Nylon Flat Washer, 3/4" O.D.	1
-	#8 Flat Washer, SAE, Plated	1



### WARNING

It is highly recommended that front "helper springs", "airshocks", or other similar devices be installed onto this vehicle to prevent the front suspension from "bottoming out" while carrying a snow plow.

Vehicle must be properly "ballasted" by placing ballast weight behind the centerline of Rear Axle so that no more than 62% of the total weight of the Vehicle, Snow Plow, Driver, Ballast weight, (and any cargo) is placed on the Front Axle while at the same time not exceeding the Gross Vehicle Weight Rating and Front or Rear Gross Axle Weight Ratings.

# 1FK20 Mounting

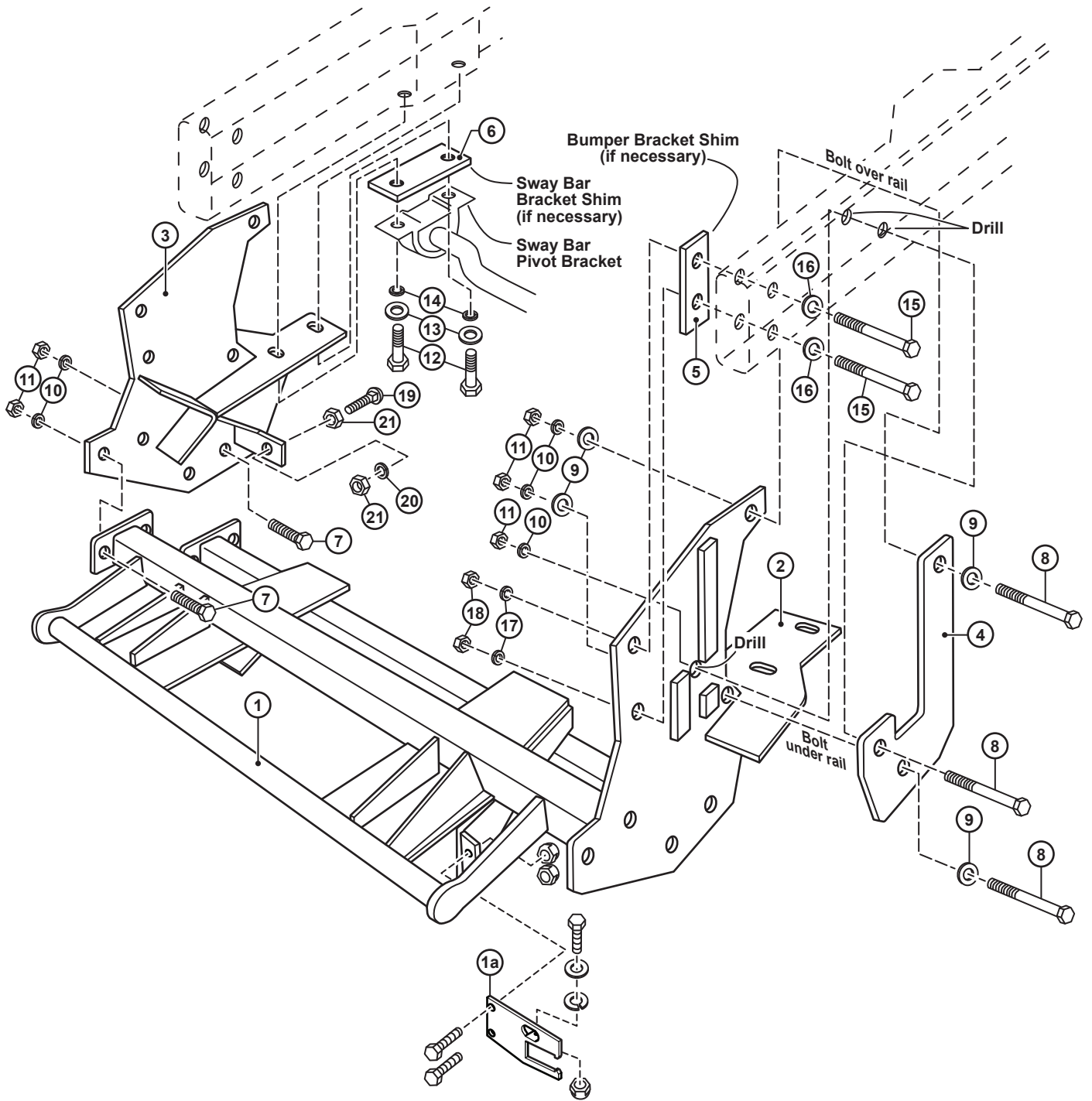

**Curtis Industries, LLC. reserves the right to change product design or specifications without notice or liability. Curtis Snow Plows and Truck equipment should only be used on vehicles equipped with the manufacturer's Snow Plow preparation package. Snow Plowing without the original snow plow preparation package may damage your vehicle and the added weight of the equipment may impair the operation and control of the vehicle.**

# 1FK20: 2003 – Dodge 2500, 3500 4WD

## Mounting Kit Installation Instructions

### 1. VEHICLE PREPARATION

- (1a.) If the vehicle has an air dam attached to the front bumper, either remove it completely, or trim out a section approximately 26" long from the center of it.
- (1b.) **VEHICLES WITH DEISEL ENGINE ONLY:** Loosen the two 10mm bolts holding the intercooler to it's bracket. Slide the intercooler up on it's bracket to gain access to bumper bracket bolts.
- (1c.) **ALL VEHICLES:** Remove and discard the four 12mm bolts and nuts holding the front bumper brackets to the ends of the frame rails. Remove and discard the four 10mm bolts and washers holding the front sway bar to the brackets on the frame rails. Screw a 5/8"-11 Hex Jam Nut (21) all the way onto each of the 5/8"-11 x 2-1/2" Carriage Bolts (19). Place each Carriage Bolt / Jam Nut assembly through the ears on the Driver's Side and Passenger's Side Push Arms (2 & 3) with the heads of the Carriage Bolts toward the front of the vehicle. Fasten loosely using a 5/8" Lock Washer (20) and 5/8"-11 Hex Jam Nut (21) on each Carriage Bolt / Jam Nut assembly.



#### NOTE

All fasteners should remain loose or "finger tight" until all components have been attached to vehicle or installation instructions specify tightening.

### 2. DRIVER'S SIDE PUSH ARM

- (2a.) Place a 12mm Flat washer (16) onto each of two 12mm -1.75 x 110mm Bolts (15). From the outside of the frame rail, insert the two 12mm bolts with flat washers into the holes that the original equipment 12mm bolts were removed from.
- (2b.) **VEHICLES WITHOUT TOW HOOKS AND BRACKETS:** Place a Bumper Bracket Shim (5) onto the ends of the 12mm-1.75 x 110mm Bolts (15).
- (2c.) **VEHICLES WITH TOW HOOKS AND BRACKETS:** Do not use the Bumper Bracket Shim (5).
- (2d.) **ALL VEHICLES:** Line up the two holes in the upper front section of the Driver's Side Push Arm (2) with the two 12mm-1.75 x 110mm Bolts (15) installed in the Driver's side frame rail. Fasten using two 12mm Lock Washers (17) and 12mm -1.75 Hex Nuts (18). Place a 1/2"-13 x 4 Bolt (8) and 1/2" Flat Washer (9) through the hole in the long arm of a Clamp Bar (4). From the outside of the frame rail, install the threaded end of the 1/2" bolt with Clamp Bar (4) over the top of the frame rail and through the hole in the upper rear section of the Driver's Side Push Arm (2). Fasten using a 1/2" Flat Washer (9), 1/2" Lock Washer (10) and 1/2"-13 Hex Nut (11). Install an additional 1/2"-13 x 4 Bolt (8) and 1/2" Flat Washer (9) into the lower hole in the Clamp Bar (4), under the frame rail and through the hole in the middle rear section of the Driver's Side Push Arm (2). Fasten using a 1/2" Flat Washer (9), 1/2" Lock Washer (10) and 1/2"-13 Hex Nut (11).

### 3. PASSENGER'S SIDE PUSH ARM

Install the Passenger's Side Push Arm (3) in the same sequence and with the same amount and type of fasteners as the Driver's Side Push Arm (2).

### 4. MOUNTING FRAME

- (4a.) Lift the Mounting Frame (1) up under the front of the vehicle with the eight holes in the front and rear cross tube end brackets lined up with the eight holes in the lower sections of the Driver's and Passenger's Side Push Arms (2 & 3) Fasten using eight 1/2"-13 x 1-1/2" Bolts (7), 1/2" Lock Washers (10), and 1/2"-13 Hex Nuts (11).
- (4b.) Swing the vehicle sway bar up into position so that the holes in the sway bar pivot brackets line up with the holes in the rear plates of the Driver's & Passenger's Side Push Arms (2 & 3) and the tapped holes in the sway bar brackets on the frame rails. Fasten using four 10mm-1.5 x 40mm Bolts (12), 10mm Flat Washers (13), and 10mm Lock Washers (14). A 1/8" thick Sway Bar Bracket Shim (6) is provided to help in leveling the Mounting Frame (1).
- (4c.) If the Mounting Frame (1) sits level from side to side, do not use the shim. If the Mounting Frame (1) does not sit level from side to side, place this shim between either the Driver's Side or Passenger's Side Push Arm rear plate and sway bar bracket on the frame rail to level the Mounting Frame (1).

### 5. DRILLING AND TIGHTENING

- (5a.) Tighten the 12mm Bolts and Nuts (15 & 18) and 10mm Bolts (12) holding the sway bar and Driver's Side and Passenger's Side Push Arms (2 & 3) to the vehicle frame rails and sway bar brackets. Tighten the 1/2" fasteners holding the front and rear cross tube end plates (on the Mounting Frame (1), to the Driver's Side and Passenger's Side Push Arms (2 & 3).
- (5b.) Check the Mounting Frame (1) to be sure it is reasonably level with the ground. If it is not loosen all fasteners and realign using the Sway Bar Bracket Shim (6) then retighten all fasteners.
- (5c.) Adjust the 5/8"-11 x 2-1/2" Carriage Bolts (19) with the front 5/8" Jam Nuts (21) so that the heads of the Carriage Bolts are tight against the back of the rear cross tube of the Mounting Frame (1). Lock the 5/8"-11 x 2-1/2" Carriage Bolts (19) in place using the rear 5/8"-11 Jam Nuts (21).
- (5d.) Using the remaining open holes in the in the Driver's Side and Passenger's Side Clamp Bar (4), drill 1/2" dia. holes through both surfaces of each frame rail and Push Arm (2 & 3). Insert a 1/2"-13 x 4 Bolt (8) through each Clamp Bar (4), frame rail, and Push Arm (2 & 3). Fasten and tighten using 1/2" Lock Washer (10), and 1/2"-13 Hex Nut (11).

### 6. FINAL ADJUSTMENT AND INSPECTION

- (6a.) Install the Vehicle Wiring Harness at this time and make the parking and directional signal wire connections.
- (6b.) Inspect the vehicle and mounting attachment bolts to be certain that they are all in place and that they are all tight.

