



HOME-PRO[®] 3000

**2002 – Jeep Liberty V6
(With Max. GVWR & Max. FGAWR ONLY)**

Vehicle Mounting Kit: 1FK31

Revised 14 February 2011

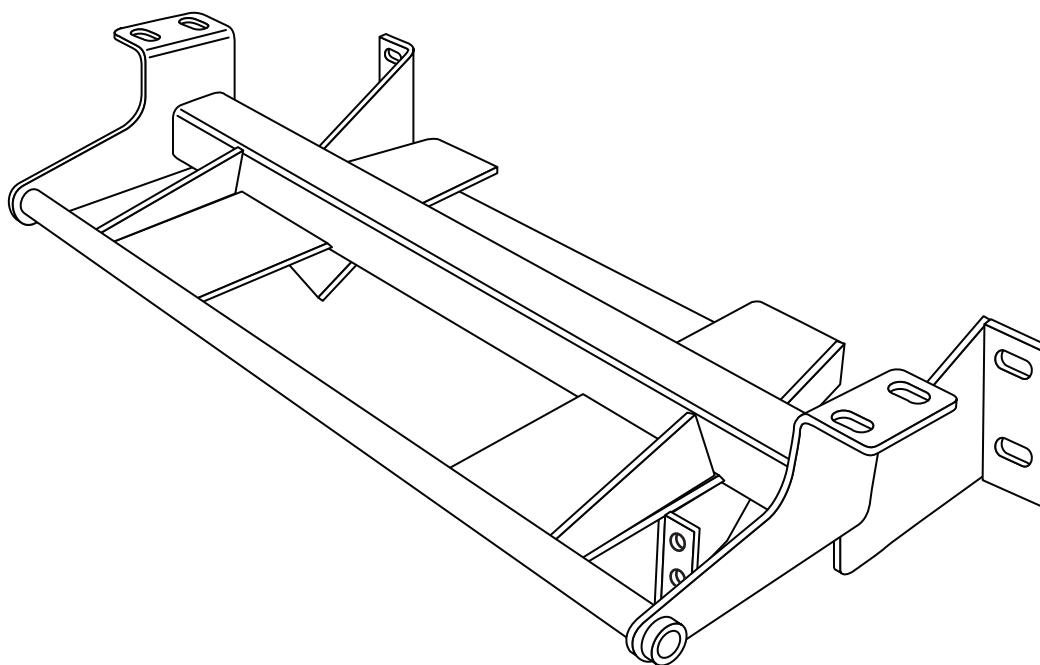

Curtis Industries Inc. LLC, 111 Higgins St., Worcester, MA 01606 TEL: (800) 343-7676 FAX: (508) 854-3377 For Parts and information visit us at www.Curtisindustries.net
Curtis Industries Inc. LLC, reserves the right to change product design or specifications without notice or liability.
Curtis Snow Plows are protected by the following U.S. Patent Numbers: 6,145,222 and 6,209,231 Licensed under U.S. Patent Number 5,568,694 & Canadian Patent Number 2,137,853.
Other patents pending.

1FK31 Vehicle Mount Kit Parts List

Item #	Description	Qty.
1	Mounting Frame	1
2	Bolting Bar	2
3	Pipe Spacer, 2-9/16" Long	4
Hardware Bag Components Included In This Kit		
4	M12-1.75 x 50MM Bolt, Plated, Gr. 9.8	4
5	M12 Lock Washer, Plated	8
6	M12 Flat Washer, Plated	4
7	M12-1.75 x 38MM Long, Coupling Nut, Plated	4
8	1/2"-13 x 1-1/2" Bolt, Gr.5, Plated	4
9	1/2" Lock Washer, Plated	4
10	1/2" Flat Washer, Plated	4
Hardware Components Included In Plow Kit		
1a	Dual Plug Harness Bracket	1
-	10-32 x 3/4" Hex Head Screw, Plated	2
-	10-32 Nylock Lock Nut, Plated	2
-	8-32 x 1" Hex Head Screw, Plated	1
-	8-32 Nylock Lock Nut, Plated	1
-	#8 Nylon Flat Washer, 3/4" O.D.	1
-	#8 Flat Washer, SAE, Plated	1



WARNING

It is highly recommended that front "helper springs", "airshocks", or other similar devices be installed onto this vehicle to prevent the front suspension from "bottoming out" while carrying a snow plow.

Vehicle must be properly "ballasted" by placing ballast weight behind the centerline of Rear Axle so that no more than 62% of the total weight of the Vehicle, Snow Plow, Driver, Ballast weight, (and any cargo) is placed on the Front Axle while at the same time not exceeding the Gross Vehicle Weight Rating and Front or Rear Gross Axle Weight Ratings.

1FK31 Mounting

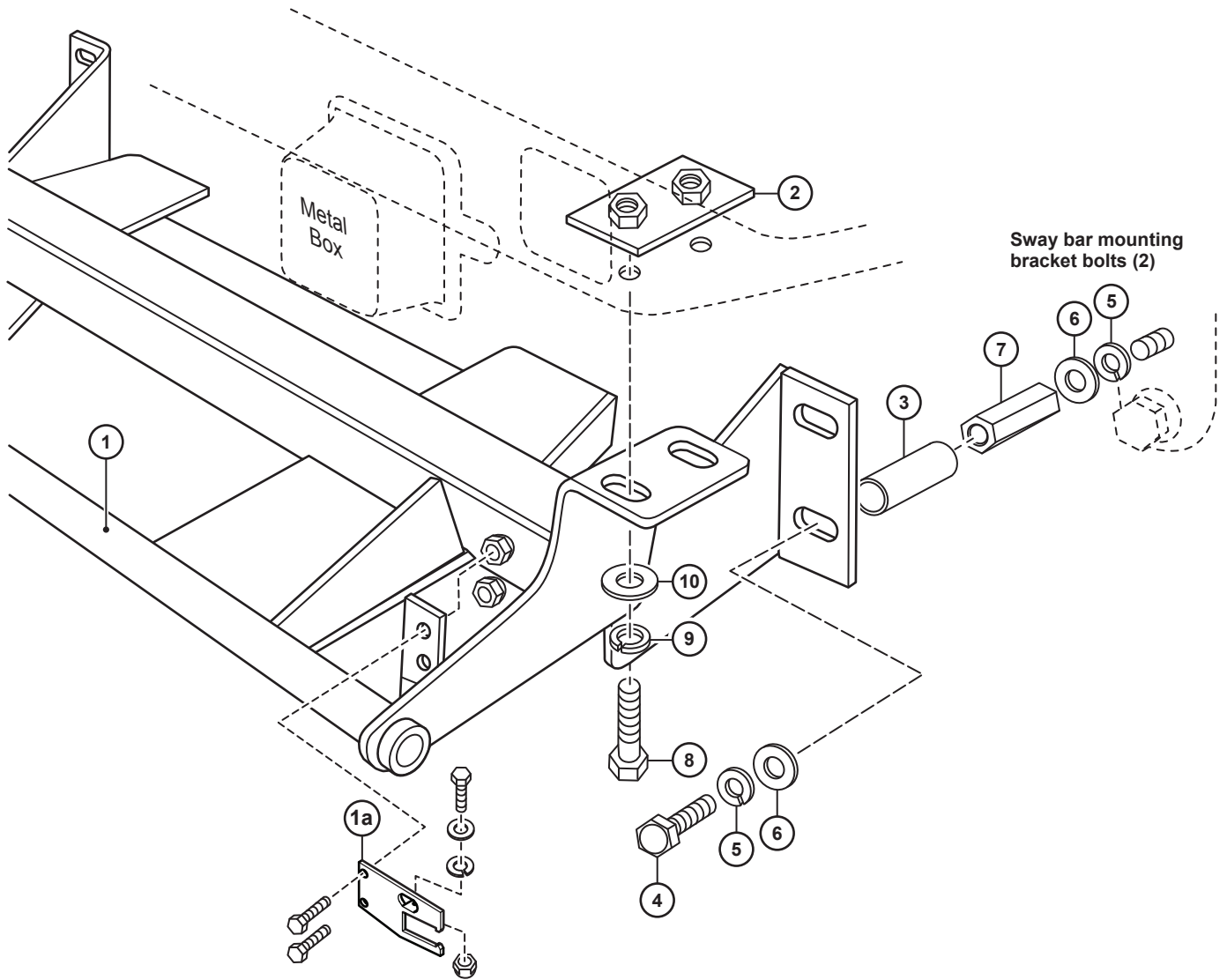

Curtis Industries, LLC. reserves the right to change product design or specifications without notice or liability. Curtis Snow Plows and Truck equipment should only be used on vehicles equipped with the manufacturer's Snow Plow preparation package. Snow Plowing without the original snow plow preparation package may damage your vehicle and the added weight of the equipment may impair the operation and control of the vehicle.

1FK31: 2002- Jeep Liberty V6

Mounting Kit Installation Instructions

1. VEHICLE PREPARATION

- (1a.) Remove the vehicle grill, plastic front bumper cover (with air dam) and the two metal "box" covers attached to the front vehicle cross member behind the bumper cover. Save all the original equipment fasteners for reinstallation.
- (1b.) Trim a section approximately 30" wide x 5" high from the center of the bumper cover and air dam.
- (1c.) Using a 9/16" drill, ream out the four vertical holes in the bottom surface of the front vehicle cross member. Place a bolting bar (2) inside the front vehicle cross member through each of the large holes in the front surface that were covered by the metal "box" covers removed earlier.
- (1d.) Remove and discard the two 12mm nuts holding each of the sway bar mounting brackets to the front of the vehicle front suspension frame. Install 12mm-1.75 x 38mm coupling nuts (7) and 12mm lock washers (5) onto the sway bar mounting bracket bolts that nuts were removed from. Tighten the 12mm coupling nuts (7) to 65 ft./lb. Place a pipe spacer (3) on over each of the coupling nuts (7).



NOTE

All fasteners should remain loose or "finger tight" until all components have been attached to Vehicle or installation instructions specify tightening.

2. MOUNTING FRAME

- (2a.) Lift the mounting frame (1) up under the front of the vehicle with the holes in the front horizontal brackets lined up with the reamed out holes in the bottom surface of the front vehicle cross member. Fasten using 1/2"-13 x 1-1/2" bolts (8), 1/2" lock washers (9), and 1/2" flat washers (10) up through the horizontal brackets, through the bottom surface of the cross member, threaded into the bolting bars (2) inside the cross member.
- (2b.) Fasten the rear vertical brackets of the mounting frame (1) to the open ends of the coupling nuts (7) using 12mm-1.75mm x 50mm bolts (4), 12mm lock washers (5), and 12mm flat washers (6). Tighten the 1/2"-13 bolts (8) to 75 ft./lb. and the 12mm-1.75mm bolts (4) to 65 ft./lb.

3. FINAL ADJUSTMENT AND INSPECTION

- (3a.) Reinstall and tighten the two metal "box" covers back onto the vehicle cross member using the original equipment screws.
- (3b.) Reinstall the trimmed plastic bumper cover (with air dam), and grill back onto the vehicle using the original equipment fasteners.
- (3c.) Inspect the mounting frame attachment bolts and reused original equipment fasteners to be certain that they are all in place and that they are all tight.

4. OPTIONAL PLUG MOUNT BRACKET INSTALL



NOTE

Install the Plug Mount Bracket if the harness will be mounted on the frame kit, otherwise, the harness may be routed through the grill, bumper, etc.

Using (2) 10-32 x 3/4" hex bolts and nylon locknuts, fasten the Plug Mount Bracket to the Plug Mount Bracket Mounting Tab located on the drivers side of the frame kit receiver. The included 8-32 hardware is used for mounting the hi-amp battery leads to the Plug Mount Bracket, if used.

